



INTERNATIONAL JOURNAL
OF RESEARCH IN
APPLIED SCIENCES

ISSN

INTERNATIONAL JOURNAL OF RESEARCH IN APPLIED SCIENCES

Vol. 2 Issue 2 (July- Dec)-2025

Research & Development Cell
GITA Autonomous College, Bhubaneswar
Badaraghunathpur, Odisha, India, 752054



INTERNATIONAL JOURNAL OF RESEARCH IN APPLIED SCIENCES



Published by
Research & Development Cell
GITA Autonomous College, Bhubaneswar
Badaraghunathpur, Odisha, India, 752054
Website : www.ijras.edu.in
Email : ijras@gita.edu.in



International Journal of Research in Applied Sciences

Vol 2 Issue 2 (July – December) 2025

EDITORIAL ADVISORY BOARD

Prof. (Dr.) S.K. Sarangi

Former Director NIT Rourkela

Prof. (Dr.) R.R. Dash

Retd. Scientist NML, Jamshedpur

Prof. (Dr.) S. Chattiopodhyya

NITTTR, Kolkata

Prof. (Dr.) B.N. Pattnaik

IIT, Bhubaneswar

Prof. (Dr.) Mrutyunjaya Panda

Utkal University, Bhubaneswar

Prof. (Dr.) S.K. Meher

ISI, Bangalore

Prof. (Dr.) S. K. Dash

IIT, Kharagpur

Prof. (Dr.) P.K. Satpathy

CET, Bhubaneswar

Prof. (Dr.) A.K. Chakravarti

Retd. Prof.IIT, Kharagpur

Prof. (Dr.) B.K. Panda

IGIT, Sarang

Prof. (Dr.) Sasikumaran Sreedharan

Prof. & Head KKU, Saudi Arabia

Prof. (Dr.) Ashish Rastogi

UTAS, Muscat, Oman

Executive Editors

Prof. (Dr.) Manmatha Kumar Roul

Email ID : mkroul@gmail.com, Mob : 8260045006

Prof. (Dr.) Bishnu Prasad Mishra

E.mail: dean.rd@gita.edu.in, Mob: +918249554099

Editor-in-Chief

Prof. (Dr.) Parimal Kumar Giri

E.mail: parimal.6789@gmail.com, Mob: +917873764933

Editorial Board Members

Prof. (Dr.) Kishore Kumar Mishra

GITA Autonomous College, BBSR

Prof. (Dr.) Tarini Prasad Panigrahy

GITA Autonomous College, BBSR

Prof. (Dr.) Narendra Kumar Kamila

GITA Autonomous College, BBSR

Prof. (Dr.) Manoj Kumar Pradhan

GITA Autonomous College, BBSR

Prof. (Dr.) Prasanta Kumar Bal

GITA Autonomous College, BBSR

Prof. (Dr.) S. P. Mohanty

GITA Autonomous College, BBSR

Prof. (Dr.) Shailendra Gupta

J.C Bose (YMCA), Faridabad Hariyana

Prof. (Dr.) S.N. Mohanty

SCOPE, VIT, AP

Prof. (Dr.) S.K. Baral

IGNTU, Amarkantak, MP

Dr. Sagar S De

SN Bose, Kolkata

Published by GITA R & D cell, on behalf GITA Autonomous College, Bhubaneswar-752054. International Journal of Research in Applied Sciences is issued bimonthly by GITA R & D cell, GITA and assumes no responsibility for the statements and opinions advanced by the contributors. The editorial staff in the work of examining papers received for publication is assisted, in an honorary capacity, by a large number of distinguished scientists and engineers.

Communications regarding contributions for publication in the journal should be addressed to the Editor-in-Chief: International Journal of Research in Applied Sciences. GITA R & D Cell, GITA Autonomous College, Bhubaneswar-752054. Correspondence regarding subscriptions and advertisement should be addressed to the Sales & Distribution Officer, GITA R & D Cell, GITA Autonomous College, Bhubaneswar-752054. Badaragunathpur, Bhubaneswar 752054. Annual subscription: Rs. 2000/- \$290 Single Copy: Rs.300, \$50 (inclusive of first-class mail). For inland outstation cheque, please add Rs. 50 /- and for foreign cheque, please add \$ 10.00. Payment in respect of subscriptions and advertisements may be sent by cheque / bank draft, payable to GITA R & D Cell, GITA Autonomous College, Bhubaneswar-752054, Badaragunathpur. Bank charges shall be borne by subscriber.

*Claims for missing numbers of the journal will be allowed only if received within 3 months of the date of issue of the journal plus the time normally required for postal delivery of the journals and the claim.
© 2014 GITA R & D Cell, GITA Autonomous College, Bhubaneswar-752054, Badaragunathpur.*

International Journal of Research in Applied Sciences

Vol. 2 Issue 2 (July -December) 2025

Editorial First Issue

With this first issue, we are very pleased to announce the launch of the International Journal of Research in Applied Sciences, sponsored by GITA Autonomous College, Bhubaneswar.

The International Journal of Research in Applied Sciences (IJRAS) aims to address this need and to be the main international forum for publishing papers on applied sciences and the journal intends to primarily publish papers from various disciplines illustrating different emerging technologies with real world applications.

The IJRAS will be published bi-monthly. The abstracts of the published papers, and sometimes the full papers will be available on-line on the journal page of GITA website: www.ijras.in. The journal will contain original research papers on the topics listed in “Aims and Scope”. Each paper will be thoroughly reviewed by independent reviewers.

Thanks are due to many people who have helped in starting up this new journal. We are particularly grateful to the Management of our institution, who provided us with a lot of support and advice. Further, we are also very much thankful to all our esteemed advisors, who will continue to Support us to represent the journal in their research areas. We are sure that their reputation and great expertise in the field will have a significant contribution in shaping up the journal and making IJRAS a prestigious international journal.

It is also our great pleasure to welcome the members of the Editorial Board of IJRAS. We rely on their expertise for reviewing and accepting papers to the journal. Therefore, their contribution to the journal is invaluable and we are grateful to them for giving freely of their time to review papers for the journal. We hope they will continue to help us in the future.

We are convinced that with this unreserved support from such a prominent and large team of researchers the IJRAS will become one of the most prestigious journals in the general area of applied sciences. We are fortunate to work with this team.

Finally, the Editors-in-chief wish to thank the authors who submitted papers to the first issue of IJRAS.

Any suggestion on how to improve our activity in order to deliver a better journal to the authors, readers and subscribers of this journal will be always very much appreciated.

Prof. (Dr.) Parimal Kumar Giri
December, 2025, Editors-in-chief

International Journal of Research in Applied Sciences
Vol. 2 Issue 2 (July – December) 2025

CONTENTS

Editorial	i
Papers	
1. A Modification of Birkhoff-Young Quadrature Rule for Integrals of Analytic Functions Bijaya Mishra, Biraja Shankar Bal, Rabindra Panda	1
2. A Novel Soft Computing Based Approach for Anomaly Detection Bijaya Kumar Panda, Manoj Kumar Sahu, Saswati Sahoo, Rednam S S Jyothi, Sangita Kumari Biswal	13
3. Study on Surface Drainage system of the Capital City of Bhubaneswar Chinmayananda Sahoo, Joygopal Jena, Anshu Raj, Kalyani S. Singh	21
4. Coordination in Twin Circuit Protection for Under-Reach Scenarios without Residual Current Contributions Bibhudatta Paikaray, Priyadarsini Pradhan, Rabinarayan Rout, Sahasranshu Das, Abinash Mahapatra, Kashyap Kumar	31
5. Evolutionary Algorithm for Network on Chip Architecture: A Survey V.Singh, K.P. Swain, A.S.Das, P.K.Bal, Subhashree Choudhury	41
6. Examining Corporate Social Accountability of Organizations: A Case of Tata Krosaki Refractory Limited (TRL), Odisha, India Ashwini Kumar Patra and Dr. Tattwamasi Paltasingh	56
7. Navigating the Anxieties of Selfhood: An Exploration of Booker T. Washington's The Story of My Life and My Work Rasabihari Mishra, Dr. Pranati Das, Dr. Sudarsan Sahoo, Lyndon Dominic Thomas, Pritish Bhanja	74
8. Heartbeat and body Temperature Monitoring of Bedridden Patients based on Arduino Nano Prangya Paramita Pradhan, Subhadra Pradhan, Sarita Misra, Ipsita Nirmalendu, Ananyaka Kanungo	83
9. Stress at workplace and managing techniques: An Overview Dipak Kumar Sahu, Bijaya Mishra, Bandita Dash	91
10. Cybersecurity and Data Privacy Barriers in the Banking Sector's Digital Transformation Manaswinee Madhumita Panda, Laxminarayan Dash, Priya Paul, Bijayalaxmi Panda	97

- 11. Thermal Effects on Natural Frequencies of Layered Composite Plates: A Finite Element Study 106**
Sushmita Dash, Chandrika Samal, Pradeep kumar Jena, Mannmath Kumar Roul⁴, Manoj Kumar Pradhan
- 12. Enhanced Multi-Kernel Extreme Learning Machine Framework for IoT-Driven Optimization in Energy-Efficient Agricultural Systems 115**
Prasanta Kumar Bal, Sudeep Kumar Gochhayat, Alka Dash

A Modification of Birkhoff-Young Quadrature Rule for Integrals of Analytic Functions

Bijaya Mishra^{1*}, Biraja Shankar Bal², Rabindra Panda³

¹ Department of Mathematics, GITA Autonomous College, Bhubaneswar-752054, Odisha,

Email: bijayamishra.math@gmail.com

² Department of Mathematics, GITA Autonomous College, Bhubaneswar-752054, Odisha,

Email: bbauroprakash@gmail.com

³ Department of Mathematics, GITA Autonomous College, Bhubaneswar-752054, Odisha,

Email: rabip2005@gmail.com

Corresponding author: bijayamishra.math@gmail.com

Revised on 14th July 2025 and Accepted on 20 Sep 2025

Abstract:

Family of quadrature rules of degree of exactness at least seven is proposed in this paper. The relative accuracy of the rules of same class has been determined by their asymptotic error estimates and respective error bounds. Rules have been examined by a set of test integrals.

Keywords: Quadrature rule; analytic function; degree of precision; asymptotic error estimates; error bound; singularity.

1. Introduction

Birkhoff-Young [4] have been given a quadrature rule :

$$R_{BY}(g) = \frac{h}{15} [24g(z_0) + 4\{g(z_0 - h) + g(z_0 + h)\} - \{g(z_0 - ih) + g(z_0 + ih)\}] \quad (1)$$

to approximate integrals of the type: $I(g) = \int_L g(z) dz$ (2)

Where, $g(z)$ is analytic on the disc: $\Omega = \{z \in C : |z - z_0| < \rho = r|h|; r > 1\}$

And L is the line segment joining the points $z_0 - h$ to $z_0 + h$ lying in the disk Ω .

Later Tossic [14], Acharya and Mohapatra [1,2], Das and Pradhan [7], Das and Hota [8], Jena and Dash [9], Mohanty and Dash [12], Pati and Dash [13], Milovanovic and Dordevic [11] Acharya, Senapati and Acharya [3] have modified the rule given in (1) for the numerical integration of the integrals of the type (2). However, as far as the accuracy and the applicability of a rule is concerned, this integral still attracts the attention of many researchers to devise different quadrature rules for its numerical approximations.

In this paper we have formulated a family of quadrature rules of precision seven, nine and eleven for the numerical integration of integrals of the type (1.2) which may be applicable for the approximate evaluation of real definite integrals with nearby complex singularities as well as integrals of the same class without having any kind of singularities.

2. Formulation of Rules

This section has subdivided into four subsections: subsection -3 to subsection- 4 as given below.

2.1. One Parameter Quadrature Rule:

For the construction of one parameter rule, we have chosen the nodes:

$z_0, z_0 \pm \alpha h, z_0 \pm ih$, for $0 < \alpha \leq 1$ and the rule based on these nodes is given by

$$R_g(\alpha) = w_0 g(z_0) + w_1 [g(z_0 + \alpha h) + g(z_0 - \alpha h)] + w_2 [g(z_0 + ih) + g(z_0 - ih)] \quad (3)$$

Since the rule $R_g(\alpha)$ is fully symmetric quadrature rule, thus

$$I[(z - z_0)^{2k+1}; \alpha] = R_g[(z - z_0)^{2k+1}; \alpha]; \text{ for } k = 0, 1, 2, \dots \quad (4)$$

Therefore, to determine the weights w_0, w_1 and w_2 and the parameter α , we make here the assumption that

$$I[(z - z_0)^k; \alpha] = R_g[(z - z_0)^k; \alpha]; \text{ for } k = 0, 2, 4 \quad (5)$$

which in turn leads to the following set of three linear equations in weights w_0, w_1 and w_2 and α as

$$\begin{cases} w_0 + 2(w_1 + w_2) = 2h; \\ \alpha^2 w_1 - w_2 = \frac{h}{3} \text{ and } \alpha^4 w_1 + w_2 = \frac{h}{5} \end{cases} \quad (6)$$

By solving the above set of equations with the assumptions $0 < \alpha \leq 1$, we obtain

$$w_0 = h \left[\frac{40\alpha^2 - 16}{15\alpha^2} \right]; w_1 = \frac{8h}{15\alpha^2(\alpha^2 + 1)} \text{ and } w_2 = \frac{h(3 - 5\alpha^2)}{15(\alpha^2 + 1)} \quad (7)$$

Thus, with these weights w_0, w_1 and w_2 given in equation (7), the rule $R_g(\alpha)$ given in equation (3) represents a family of one parameter five-point quadrature rules with precision at least five for numerical evaluation of the integrals (3).

2.2. Derivation of Quadrature Rule of Precision At least Seven:

Let $E_g(\alpha_1)$ and $E_g(\alpha_2)$ are the truncation errors occur in approximation of the integral $I(g)$ by the rules $R_g(\alpha_1)$ and $R_g(\alpha_2)$ respectively. Then

$$I(g) = R_g(\alpha_1) + E_g(\alpha_1); \quad (8)$$

and
$$I(g) = R_g(\alpha_2) + E_g(\alpha_2) \quad (9)$$

Now assuming, the function $f(z)$ to be analytic in the disc: $\Omega = \{z \in C : |z - z_0| < \rho = r|h; r > 1\}$;

the error terms $E_g(\alpha_j)$; $j = 1, 2$ can be written as:

$$E_g(\alpha_j) = \sum_{k=3}^{\infty} A_{2k} g^{(2k)}(z_0) \quad (10)$$

where

$$A_{2k} = \lambda_{2k} \eta_{2k}(\alpha_j), \quad \lambda_{2k} = \frac{2h^{2k+1}}{(2k)!} \text{ and} \quad (11)$$

$$\eta_{2k}(\alpha_j) = \frac{1}{2k+1} - \left[\frac{8\alpha_j^{2(k-1)} + (-1)^{k-1}(5\alpha_j^2 - 3)}{15(\alpha_j^2 + 1)} \right]; \text{ for } j = 1, 2$$

Now multiplying equation (8) and (9) by $\eta_6(\alpha_2)$ and $-\eta_6(\alpha_1)$ respectively and then adding the result we obtain

$$I(g) = \frac{1}{14(\alpha_1^2 - \alpha_2^2)} \left[(9 - 14\alpha_2^2) R_f(\alpha_1) - (9 - 14\alpha_1^2) R_f(\alpha_2) \right] \quad (12)$$

$$+ \frac{1}{14(\alpha_1^2 - \alpha_2^2)} \left[(9 - 14\alpha_2^2) E_f(\alpha_1) - (9 - 14\alpha_1^2) E_f(\alpha_2) \right]$$

which implies

$$I(g) \approx \frac{1}{14(\alpha_1^2 - \alpha_2^2)} \left[(9 - 14\alpha_2^2) R_g(\alpha_1) - (9 - 14\alpha_1^2) R_g(\alpha_2) \right] = R_g(\alpha_1, \alpha_2) \quad (13)$$

with the corresponding truncation error given by

$$E_g(\alpha_1, \alpha_2) = \frac{1}{14(\alpha_1^2 - \alpha_2^2)} \left[(9 - 14\alpha_2^2) E_g(\alpha_1) - (9 - 14\alpha_1^2) E_g(\alpha_2) \right] \quad (14)$$

The rule given in (12) is the desired family of two parametric quadrature rules of precision at least seven for the approximate evaluation of the integral of the type given in (3).

2.3. Rules of Precision Nine

Since the function $g(z)$ is analytic on the disc Ω ; therefore expanding $g(z)$ about $z = z_0$ by using Taylor's theorem with the subsequent analytic simplification we obtain:

$$E_g(\alpha_1, \alpha_2) = \frac{8h^9}{315(8!)} \left\{ (42\alpha_1^2 - 27)\alpha_2^2 + 20 - 27\alpha_1^2 \right\} \times g^{(8)}(z_0)$$

$$+ \frac{8h^{11}}{1155(10!)} \left[11(\alpha_1^2 + \alpha_2^2)(9 - 9\alpha_1^2 + 14\alpha_1^2\alpha_2^2) - 11\alpha_2^2(14\alpha_1^2 + 9\alpha_2^2) - 15 \right] \times g^{(10)}(z_0) \quad (14)$$

$$+ \dots$$

Now by taking $\alpha_1 = \sqrt{\frac{3}{4}}$ in (14) and then equating the coefficient of $g^{(8)}(z_0)$ to zero, we obtain the value of $\alpha_2 = \sqrt{\frac{1}{18}}$. With these values of α_1 and α_2 the rule $R_g(\alpha_1, \alpha_2)$ given in (12) reduces into

$$R_1(g) = R_g \left(\sqrt{\frac{3}{4}}, \sqrt{\frac{1}{18}} \right) = \frac{1}{175} \left[148R_g \left(\sqrt{\frac{3}{4}} \right) + 27R_g \left(\sqrt{\frac{1}{18}} \right) \right] \quad (15)$$

which is a seven point rule but of degree of precision nine meant for the approximate evaluation of complex line integrals of analytic functions with the truncation error given by:

$$E_1(g) = E \left(\sqrt{\frac{3}{4}}, \sqrt{\frac{1}{18}} \right) = \frac{1}{175} \left[148E_g \left(\sqrt{\frac{3}{4}} \right) + 27E_g \left(\sqrt{\frac{1}{18}} \right) \right] \quad (16)$$

Following the same technique the rules:

$$R_2(g) = R_g \left(1, \sqrt{\frac{7}{15}} \right) = \frac{1}{112} \left[37R_g(1) + 75R_g \left(\sqrt{\frac{7}{15}} \right) \right] \quad (17)$$

and

$$R_3(g) = R_g \left(\sqrt{\frac{5}{6}}, \sqrt{\frac{5}{16}} \right) = \frac{1}{175} \left[111R_g \left(\sqrt{\frac{5}{6}} \right) + 64R_g \left(\sqrt{\frac{5}{16}} \right) \right] \quad (18)$$

are obtained as two more seven point degree nine quadrature rules associated with their corresponding truncation errors:

$$E_2(g) = E_g \left(1, \sqrt{\frac{7}{15}} \right) = \frac{1}{112} \left[37E_g(1) + 75E_g \left(\sqrt{\frac{7}{15}} \right) \right] \quad (19)$$

and

$$E_3(g) = E_g \left(\sqrt{\frac{5}{6}}, \sqrt{\frac{5}{16}} \right) = \frac{1}{175} \left[111E_g \left(\sqrt{\frac{5}{6}} \right) + 64E_g \left(\sqrt{\frac{5}{16}} \right) \right] \quad (20)$$

respectively, from the rule $R_g(\alpha_1, \alpha_2)$ given in (12) meant for the numerical integrations of complex line integrals of type (3).

Several such type of quadrature rules involving seven points and of precision nine for the numerical approximation of integrals of type (3) can be formulated in the same manner.

2.4. Rules of Precision Eleven

In this subsection some quadrature rules of precision eleven for the approximate evaluation of line integrals of analytic functions of type (3) have been formulated by following method of extrapolation from the constructed rules given in (15), (17) and (18). For the construction of rules by extrapolation, we denote

$$E_k(g) = I(g) - R_k(g); \quad k = 1, 2, 3. \quad (21)$$

as the truncation error associated with the quadrature rule $R_k(f)$; $k = 1, 2, 3$. Further, since the function $g(z)$ is analytic on the disc Ω ; it can be shown that:

$$I(g) = R_1(g) + \frac{2h^{11}}{10!} \left(\frac{3659}{311850} \right) g^{(10)}(z_0) + \frac{2h^{13}}{12!} \left(\frac{19417777}{1426288500} \right) g^{(12)}(z_0) + \dots \quad (22)$$

$$I(g) = R_2(g) + \frac{2h^{11}}{10!} \left(\frac{-544}{51975} \right) g^{(10)}(z_0) + \frac{2h^{13}}{12!} \left(\frac{-1952}{131625} \right) g^{(12)}(z_0) + \dots \quad (23)$$

$$I(g) = R_3(g) + \frac{2h^{11}}{10!} \left(\frac{5}{16632} \right) g^{(10)}(z_0) + \frac{2h^{13}}{12!} \left(\frac{2389}{943488} \right) g^{(12)}(z_0) + \dots \quad (24)$$

Further by suitably combining any two of the three quadrature rules by the help of equations (22) to (24), we get:

$$I(g) = \frac{1}{14261} [-375R_1(g) + 14636R_3(g)] + \frac{2h^{13}}{12!} \left(\frac{972292063}{433926406368} \right) g^{(12)}(z_0) + \dots \quad (25)$$

$$I(g) = \frac{1}{4477} [125R_2(g) + 4352R_3(g)] + \frac{2h^{13}}{12!} \left(\frac{166}{81081} \right) g^{(12)}(z_0) + \dots \quad (26)$$

$$I(g) = \frac{1}{6923} [3264R_1(g) + 3659R_2(g)] + \frac{2h^{13}}{12!} \left(\frac{-233584592}{164569921425} \right) g^{(12)}(z_0) + \dots \quad (27)$$

We denote the first term on the right-hand side of the equation (25) by $Q_1(g)$

$$Q_1(g) = \frac{1}{14261} [-375R_1(g) + 14636 R_3(g)] \quad (28)$$

and claim that the rule $Q_1(g)$ is the required quadrature rule of precision eleven obtained from the rule $R_1(g)$ and $R_3(g)$ by extrapolation for numerical integration of complex integrals of the type (1.2) and the corresponding truncation error $E_{Q_1}(g)$ is given by:

$$E_{Q_1}(g) = \frac{1}{14261} [-375E_1(g) + 14636 E_3(g)] \quad (29)$$

Similarly two more quadrature rules $Q_2(g)$ and $Q_3(g)$, each of precision eleven are obtained by following the technique of extrapolation from the suitable combinations of quadrature rules $R_1(g)$, $R_2(g)$ and $R_3(g)$ and are given by:

$$Q_2(g) = \frac{1}{4477} [125R_2(g) + 4352R_3(g)] \quad (30)$$

with the truncation error

$$E_{Q_2}(g) = \frac{1}{4477} [125 E_2(g) + 4352 E_3(g)] \quad (31)$$

and

$$Q_3(g) = \frac{1}{6923} [3264 R_1(g) + 3659 R_2(g)] \quad (32)$$

with the corresponding truncation error

$$E_{Q_3}(g) = \frac{1}{6923} [3264 E_1(g) + 3659 E_2(g)] \quad (33)$$

For the approximate evaluation of complex integrals of the type (3). The procedure may be continued for construction of several quadrature rules of higher degree of precision involving more points.

Again, it is to be observed from equations (28),(30) and (32) that no additional evaluation of functions at any of the nodes is required when each of these rules $Q_1(g), Q_2(g)$ and $Q_3(g)$ will be employed for the approximate evaluation of complex line integrals; since each of them is a weighted mean of two rules obtain from the set of three quadrature rules $R_1(g), R_2(g)$ and $R_3(g)$. As a result, there will be no further occurrence of any additional errors like truncation error, round-off error or machine error due to the finite precision of computing machine when each of these rules has to be applied for the numerical evaluation of complex line integrals of the type (3).

It is pertinent to note here that each of the quadrature rules $Q_1(g), Q_2(g)$ and $Q_3(g)$ being of precision eleven, numerically integrates more accurately than the constituent rules meant for the evaluation of the complex line integrals and this observation has been reflected in the approximate values obtained by numerical integrations of some standard test integrals as given in Section-4.

Also, the quadrature rules have been successfully applied for the approximate evaluation of integrals of real definite integrals as well as the integrals of same class with nearby complex singularity. The results of numerical integrations are given in Section-4.

3. Error Analysis

In this section we have determined the asymptotic error bounds of degree nine quadrature rules $R_1(g), R_2(g)$ and $R_3(g)$; and rules of degree eleven $Q_1(g), Q_2(g)$ and $Q_3(g)$ respectively as constructed in this paper for the numerical integration of integrals of the type (1.2).

Further the analytic convergence of rules of precision nine have been derived by the following technique due to Lether [10] which are given in Theorem-3.1. However, the error bounds of the quadrature rules $Q_1(g)$ and $Q_2(g)$ can't be determined by following the technique due to Lether [10]. This is due to the reason given in subsection-3.4 of this section.

3.1 Asymptotic Error Estimates of Degree Nine Rules:

The first leading term of the truncation errors $E_1(g), E_2(g)$ and $E_3(g)$ associated with the quadrature rules $R_1(g), R_2(g)$ and $R_3(g)$ respectively in the approximation of $I(g)$ are given in Table-1 in order of their increasing accuracy.

Table 1. Computed value for error estimation

Rules	First Leading Term of Error Expressions
$R_1(g)$	$6.5 \times 10^{-9} h^{11} g^{(10)}(z_0)$
$R_2(g)$	$-5.8 \times 10^{-9} h^{11} g^{(10)}(z_0)$
$R_3(g)$	$1.7 \times 10^{-9} h^{11} g^{(10)}(z_0)$

From the above table it is evident that

$$|E_3(g)| \leq |E_2(g)| \leq |E_1(g)| \quad (34)$$

Further the empirical relation given in (3.1) of the asymptotic error estimates signifies the rule $R_3(g)$ will integrate more accurately to an integral of the type (3) than the rules of the same class $R_1(g)$ and $R_2(g)$. Also the rule $R_2(g)$ will give better result than the rule $R_1(g)$; when each of these two rules ($R_1(g)$ and $R_2(g)$) will be applied for the numerical integration of an integral of analytic function $g(z)$ over a line segment L joining the points $z_0 - h$ to $z_0 + h$. Next, we consider:

3.2 Analytic convergence of degree nine rules:

Theorem:3.1. If $g(z)$ is analytic on the disc: $\Omega = \{z \in C : |z - z_0| < \rho = r|h; r > 1\}$; then

- (i) $|E_1(g)| \leq 2M e_1(r)$,
- (ii) $|E_2(g)| \leq 2M e_2(r)$ and
- (iii) $|E_3(g)| \leq 2M e_3(r)$

where

$$M = \max_{|z-z_0|=\rho} |g(z)|$$

$$e_1(r) = \left| r \ln\left(\frac{r+1}{r-1}\right) - \frac{1}{175} \left[-\frac{2360}{9} + \frac{151552}{315} \left(\frac{r^2}{4r^2-3}\right) + \frac{839808}{95} \left(\frac{r^2}{18r^2-1}\right) + \frac{110}{133} \left(\frac{r^2}{r^2+1}\right) \right] \right|;$$

$$e_2(r) = \left| r \ln\left(\frac{r+1}{r-1}\right) - \frac{1}{112} \left[\frac{3072}{35} + \frac{296}{15} \left(\frac{r^2}{r^2-1}\right) + \frac{135000}{77} \left(\frac{r^2}{15r^2-7}\right) - \frac{64}{165} \left(\frac{r^2}{r^2+1}\right) \right] \right|; \text{ and}$$

$$e_3(r) = \left| r \ln\left(\frac{r+1}{r-1}\right) - \frac{1}{175} \left[\frac{1592}{15} + \frac{127872}{275} \left(\frac{r^2}{6r^2-5}\right) + \frac{4194304}{1575} \left(\frac{r^2}{16r^2-5}\right) - \frac{50}{693} \left(\frac{r^2}{r^2+1}\right) \right] \right|$$

each of which $\rightarrow 0$ as $r \rightarrow \infty$.

The quantities $e_1(r)$, $e_2(r)$ and $e_3(r)$ are defined as error constants due to Lether [10].

Since the derivation of each part of Theorem-3.1 are similar, thus we have only given the proof of part-(ii) to avoid the repetition. The rest part of the Theorem-3.1 can be proved in the same vein as it is done in case of part-(ii).

Proof-(ii):

Let $E_2(g)$ be the truncation error associated with the rule $R_2(g)$ in the approximation of the integral $I(g)$. i.e.

$$E_2(g) = I(g) - R_2(g) \quad (35)$$

We assume here that the function $f(z)$ is analytic in the disc:

$$\Omega = \{z \in \mathbb{C} : |z - z_0| \leq \rho = r|h; r > 1\}.$$

Now under this assumption $g(z)$ can be expanded by Taylor's theorem about the point $z = z_0$ as:

$$g(z) = \sum_{k=0}^{\infty} a_k (z - z_0)^k \quad (36)$$

where $a_k = \frac{g^{(k)}(z_0)}{k!}$ are the Taylor's coefficients?

Further since E_2 being a linear operator, thus from equation (3.2) and (3.3) we obtain

$$E_2(g) = \sum_{k=0}^{\infty} a_k E_2[(z - z_0)^k] \quad (37)$$

But, since the rule $R_2(g)$ is a fully symmetric quadrature rule of precision nine, thus

$$E_2[(z - z_0)^k] = 0;$$

for $k = 0(1)9$ and k as odd. As a result, equation (3.4) will reduce to

$$\begin{aligned} E_2(g) &= \sum_{\mu=5}^{\infty} a_{2\mu} E_2[(z - z_0)^{2\mu}] \\ &= \sum_{\mu=5}^{\infty} 2a_{2\mu} h^{2\mu+1} E_2((t)^{2\mu}); \\ &= \sum_{\mu=5}^{\infty} 2a_{2\mu} h^{2\mu+1} \varphi(\mu) \end{aligned} \quad (38)$$

where

$$\varphi(\mu) = \frac{2}{2\mu+1} - \frac{1}{112} \left[\frac{296}{15} + \frac{9000}{77} \left(\frac{7}{15}\right)^\mu - \frac{64}{165} (-1)^\mu \right];$$

by using the transformation $z = z_0 + ht$; for $t \in [-1, 1]$.

Now by using the Cauchy-Inequality [6], from equation (3.5) we obtain

$$|E_2(g)| \leq 2M \sum_{\mu=5}^{\infty} \frac{1}{r^{2\mu}} |E_2(t^{2\mu})|. \quad (39)$$

Further since; for μ is odd;

$$\begin{aligned} \varphi(\mu) &= \frac{2}{2\mu+1} - \frac{1}{112} \left[\frac{296}{15} + \frac{9000}{77} \left(\frac{7}{15}\right)^\mu + \frac{64}{165} \right] \\ &< \frac{2}{2\mu+1} - \frac{143}{840} < 0; \mu \geq 6; \text{ and} \end{aligned}$$

for μ is even;

$$\begin{aligned} \varphi(\mu) &= \frac{2}{2\mu+1} - \frac{1}{112} \left[\frac{296}{15} + \frac{9000}{77} \left(\frac{7}{15}\right)^\mu - \frac{64}{165} \right] \\ &< \frac{2}{2\mu+1} - \frac{133}{770} < 0; \mu \geq 6 \quad ; \end{aligned}$$

thus by using the technique due to Lether [10] we get

$$|E_2(g)| \leq 2Me_2(r); \text{ where}$$

$$e_2(r) = \left| E_2 \left[\left(1 - \frac{t}{r} \right)^{-1} \right] \right|$$

$$= \left| r \ln \left(\frac{r+1}{r-1} \right) - \frac{1}{112} \left[\frac{3072}{35} + \frac{296}{15} \left(\frac{r^2}{r^2-1} \right) + \frac{135000}{77} \left(\frac{r^2}{15r^2-7} \right) - \frac{64}{165} \left(\frac{r^2}{r^2+1} \right) \right] \right|;$$

which $\rightarrow 0$ for $r \rightarrow \infty$. This implies $E_2(g) \rightarrow 0$ for $r \rightarrow \infty$. Hence the theorem is established.

3.3 Comparative Analysis of Error Constants

The numerical values of error constants $e_1(r)$, $e_2(r)$ and $e_3(r)$ for $r > 1$ associated with the degree nine quadrature rules $R_1(g)$, $R_2(g)$ and $R_3(g)$ are given in Table-2. The graph drawn based on these tabulated values is depicted in Fig-1. From the graph and the Table-2 it is evident that:

$$e_3(r) < e_2(r) < e_1(r) \tag{40}$$

Which further reveals that the rule $R_3(g)$ will give results of maximum accuracy when the rule $R_3(g)$ or any one of the rule of its class is to be applied for the numerical integration of an integral of the type (1.2) in its class. This fact is very much noticed in the numerical approximations of the integrals given in Section-4.

Table 2. The numerical values of error constants

r	$e_1(r)$	$e_2(r)$	$e_3(r)$
1.8	0.00010690	0.00010556	0.00001048
2.1	0.00001955	0.00001872	0.00000147
2.6	0.00000203	0.00000189	0.00000011
3.2	0.00000023	0.00000022	0.00000001
3.9	0.00000003	0.00000003	0.00000000

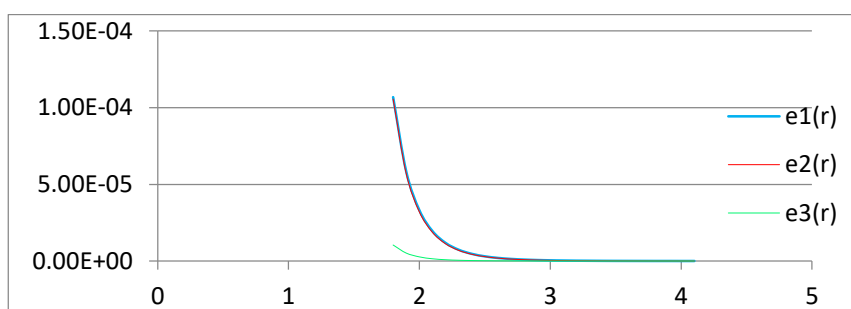

Figure 1: Results of maximum accuracy when the rule

3.4 Error Estimates of Rules of Degree Eleven:

As stated above, the error bounds of the quadrature rules $Q_1(g)$ and $Q_2(g)$ can't be determined by following the technique due to Lether[10] because of the following.

Here

$$\begin{aligned}
 E_{Q_1}(g) &= \sum_{\mu=5}^{\infty} a_{2\mu} E_{Q_1}[(z - z_0)^{2\mu}] \\
 &= \sum_{\mu=5}^{\infty} 2a_{2\mu} h^{2\mu+1} \psi(\mu)
 \end{aligned}
 \tag{41}$$

and

$$\begin{aligned}
 E_{Q_2}(g) &= \sum_{\mu=5}^{\infty} a_{2\mu} E_{Q_2}[(z - z_0)^{2\mu}] \\
 &= \sum_{\mu=5}^{\infty} 2a_{2\mu} h^{2\mu+1} \chi(\mu)
 \end{aligned}
 \tag{42}$$

where

$$\begin{aligned}
 \psi(\mu) &= \frac{2}{2\mu+1} - \frac{1}{14261} \left[\frac{311922432}{48125} \left(\frac{5}{6}\right)^\mu + \frac{3836739584}{275625} \left(\frac{5}{16}\right)^\mu - \frac{37888}{147} \left(\frac{3}{4}\right)^\mu - \frac{139968}{133} \left(\frac{1}{18}\right)^\mu - \frac{719518}{92169} (-1)^\mu \right] \\
 ; \text{ and } \quad \chi(\mu) &= \frac{2}{2\mu+1} - \frac{1}{4477} \left[\frac{925}{42} + \frac{140625}{1078} \left(\frac{7}{15}\right)^\mu + \frac{92749824}{48125} \left(\frac{5}{6}\right)^\mu + \frac{1140850688}{275625} \left(\frac{5}{16}\right)^\mu - \frac{50}{99} (-1)^\mu \right]
 \end{aligned}$$

by using the transformation $z = z_0 + ht$; for $t \in [-1, 1]$.

But, $\psi(\mu)$ and $\chi(\mu)$ are not of one sign for $\mu \geq 6$; which is the necessary condition to determine the error bound of a quadrature rule by following the technique due to Lether[10].

However, the asymptotic error bounds of the degree eleven quadrature rules $Q_1(g)$, $Q_2(g)$ and $Q_3(g)$ are depicted in Table-3. From the table it can be concluded as the rule $Q_3(g)$ is the rule of maximum accuracy among all the degree eleven quadrature rules $Q_1(g)$, $Q_2(g)$ and $Q_3(g)$ meant for the numerical integration of integrals of the type (3).

Table 3: Symptotic error bounds of the degree eleven quadrature rules

Rules	First Leading Term of Error Expressions
$Q_1(g)$	$9.4 \times 10^{-12} h^{13} f^{(12)}(z_0)$
$Q_2(g)$	$8.4 \times 10^{-12} h^{13} f^{(12)}(z_0)$
$Q_3(g)$	$-5.9 \times 10^{-12} h^{13} f^{(12)}(z_0)$

4. Numerical Experiments

In this section, at first rules $R_1(g)$, $R_2(g)$, $R_3(g)$, $Q_1(g)$, $Q_2(g)$ and $Q_3(g)$ as constructed in this paper have been examined by numerically integrating the standard test integral

$$I = \int_{-i}^i e^z dz;$$

already approximated by other researchers [1,2,3], [14] and [11].

Further, these rules are also applied for the approximate evaluation of real definite integral:

$$J = \int_0^1 e^{-x^2} dx.$$

without having any kind of singularities.

Again, these rules are also employed for the numerical evaluation of real definite integrals:

$$K_1 = \int_0^1 \frac{1}{1+x^2} dx \quad \text{and} \quad K_2 = \int_0^1 \frac{1}{1+x^4} dx$$

with nearby complex singularities at $x = \pm i$ and $x = \pm\sqrt{i}$ respectively.

The results of numerical approximations are given in Table-4 to Table-6 respectively.

Table 4. The results of numerical approximations

Rules/Integral	Approx. of $I = \int_{-i}^i e^z dz$	Abs. Error
$R_1(g)$	1.682941976020 i	6.4×10^{-9}
$R_2(g)$	1.682941963909 i	5.7×10^{-9}
$R_3(g)$	1.682941969771 i	1.5×10^{-10}
$Q_1(g)$	1.682941969607 i	1.1×10^{-11}
$Q_2(g)$	1.682941969607 i	1.1×10^{-11}
$Q_3(g)$	1.682941969618 i	0.0
Exact Value	1.682941969618 i	**

Table 5. The results of numerical approximations

Rules/Integral	Approx. of $J = \int_0^1 e^{-x^2} dx$	Abs. Error
$R_1(g)$	0.7468240803	5.2×10^{-8}
$R_2(g)$	0.7468241791	4.6×10^{-8}
$R_3(g)$	0.7468241320	8.5×10^{-10}
$Q_1(g)$	0.7468241333	5.1×10^{-10}
$Q_2(g)$	0.7468241333	4.7×10^{-10}
$Q_3(g)$	0.7468241328	0.0
Exact Value	0.7468241328	**

Table 6. The results of numerical approximations

Rules	Approx. of $K_1 = \int_0^1 \frac{1}{1+x^2} dx$	Abs. Error	Approx. of $K_2 = \int_0^1 \frac{1}{1+x^4} dx$	Abs. Error
$R_1(g)$	0.7853989	6.9×10^{-7}	0.86689	7.7×10^{-5}
$R_2(g)$	0.7853976	5.7×10^{-7}	0.86703	6.4×10^{-5}
$R_3(g)$	0.7853981	1.1×10^{-7}	0.86698	1.0×10^{-5}

$Q_1(g)$	0.7853981	1.1×10^{-7}	0.86697	0.0
$Q_2(g)$	0.7853981	1.1×10^{-7}	0.86697	0.0
$Q_3(g)$	0.7853982	0.0	0.86697	0.0
Exact Value	0.7853982	**	0.86697 (Ref. [11])	**

The integrals K_1 and K_2 have nearby complex singularities at $x = \pm i$ and $x = \pm\sqrt{i}$ respectively. The region of convergence of these two integrals is:

$$R = \{z : |z| \leq 1\} \cup \{z : |z-1| \leq 1\}.$$

Since the complex singularity $x = \pm\sqrt{i}$ lies inside the region of convergence in case of the integral K_2 thus it affects to the results of approximations. Further, the complex singularity $x = \pm i$ lies on the region of convergence in case of the integral K_1 and in this case the rule $Q_3(g)$ provides seven decimal accuracy to the exact value.

5. Conclusion

It is practically observed that the rules constructed in the paper for the numerical integration of integrals of complex analytic functions over a line segment L joining the points $z_0 - h$ to $z_0 + h$ are agreed with the exact value from nine decimal places to twelve decimal places and shows an increasing order of accuracy. Thus, for any practical purpose when an integral of the type (1.2) is need to be approximated and at least nine decimal places of accuracy is to be required, then one can take these rules into the consideration.

Reference

- [1] Acharya, M, Senapati, S and Acharya, B.P, on numerical integration of analytic functions, *Applied mathematical sciences*, vol.5, no.69, pp. 3411-3420,2011.
- [2] Pati, A and Dash, R.B, A mixed quadrature rule for numerical integration of analytic functions; *J. comp. and math. sci.* vol.3(5), 526-529, 2012.
- [3] Mohanty S and Dash R.B, A mixed quadrature rule for numerical integration of analytic functions by using Birkhoff-Young and Bools, vol.2(5), 533-545, 2016
- [4] Das, R.N and Hota, M.K, On numerical integration of analytic functions of one complex variable, *Int. J. Math. Reas.* vol.3, no. 1, pp.79-88
- [5] Acharya,M, Senapati, S and Acharya, B.P, On numerical integration of analytic functions, *Applied mathematical sciences*, vol.5, no.69, pp. 3411-3420.
- [6] Jena S.R and Dash R. B, Mixed quadrature of Birkhoff-Young and Weddle's transformed rule, *Ind. J. of math. and math. sc.*, vol.5, no.1, pp.29-32.

A Novel Soft Computing Based Approach for Anomaly Detection

Bijaya Kumar Panda¹, Manoj Kumar Sahu², SaswatiSahoo³, RednamS S Jyothi⁴, Sangita Kumari Biswal⁵

¹Department of CSE., GITA Autonomous College, Bhubaneswar-752054, Odisha
Email: bijaya_cse@gita.edu.in

²Department of CSE., GITA Autonomous College, Bhubaneswar-752054, Odisha
Email: manojkumarsahu5@gmail.com

³Department of CSE., GITA Autonomous College, Bhubaneswar-752054, Odisha
Email: saswati_cse@gita.edu.in

⁴Department of CSE., GITA Autonomous College, Bhubaneswar-752054, Odisha
Email: sujanajyothi2610@gmail.com

⁵Department of CSE., GITA Autonomous College, Bhubaneswar-752054, Odisha
Email: sangita.biswal95@gmail.com

Corresponding Author: bijaya_cse@gita.edu.in

Revised on 12th July 2025 and Accepted on 26th Nov 2025

Abstract:

Keeping computer networks safe from threats is very important. A detection system for intruders (IDS) is software that checks data from computers or networks to spot intruders. It uses soft computing methods like anomaly detection and rule-based systems with simple if-then rules. Network behaviour can be normal or harmful, so finding key details is important for accurate threat detection. This research aims to create an IDS using soft computing to reduce errors.

Key words: Fuzzy Decision Module, FIS- Fuzzy Inference Engine, FRBS-Fuzzy Rule Based System

1. INTRODUCTION

Computer security is very important today because we depend a lot on computers and its networks [1]. An intrusion occurs when someone attacks or gets into a computer or its network without permission. To detect these intrusions, tools called Intrusion Detection Systems (IDS) are created using smart computing techniques. Many organizations now use Intrusion Detection and Prevention Systems (IDPS), which not only detect threats but also record and study them. There are two types of intrusion detection: Misuse Detection and Anomaly Detection [2]. Misuse Detection, also called Signature-Based Detection, is good at finding known attacks but cannot detect new ones. Anomaly Detection, however, is better at finding new, unknown attacks by spotting unusual behaviour that differs from normal activity, even when attackers try to hide [3]. This research uses fuzzy logic and neural networks together to create, test, and improve an Anomaly-Based Intrusion Detection System. Combining these methods makes intrusion detection more flexible and effective. The study explains how fuzzy logic and neural networks work together to get better results.

2. PREVIOUS WORK

Many methods have been developed to detect intrusions and abnormal activities in computer systems. One of the first systems, the Intrusion Detection Expert System (IDES) [4], was created at Stanford Research Institute. It focused on monitoring user behaviour to spot suspicious activities. In [5], a method for detecting intrusions more effectively is proposed. In [6], Denning suggested that any changes in a user's normal behaviour should be considered an anomaly. The Stanford Research Centre created an Expert System to track user events and compare them with audit profiles. If a change in activity is detected, an alarm is triggered.

In [7], it is mentioned that many intrusion detection systems (IDS) were built using expert system technology, but they were often hard to use and lacked good interfaces. To fix this, fuzzy sets were used in an adaptive system to better detect attacks. In [8], a method combining fuzzy logic and Bayesian classifiers was introduced to detect real-time network anomalies and suspicious activities. This combination improved the performance of intrusion detection systems. In [9], a hybrid model using fuzzy logic and data mining techniques was explained to detect both misuse and anomaly attacks. The goal was to reduce the amount of data processing needed and improve detection rates

by using attribute selection and data mining methods. They used an improved fuzzy data mining algorithm for faster decision-making. In [10], a backpropagation model for intrusion detection was discussed. This method used training pairs of input and output data to improve detection. However, the detection rate for attacks like U2R, R2L, DoS, and Probe was less than 80%, and it was not very effective in detecting hidden attackers.

3. USED DATASET(S)

As computer networks become more common, cyber-attacks and new hacking tools are also increasing. This research aims to develop an anomaly-based network intrusion detection system using advanced computing methods. For this, the "KDD Cup 1999 dataset" has been chosen for analysis. It contains 41 features that are labeled as either normal or attack. [11] (From Table 1). The KDD Cup 1999 dataset is based on the "DARPA 1998 dataset", which was created by DARPA with MIT's Lincoln Laboratory to test intrusion detection systems. [12]. This dataset includes 38 different types of attacks. The raw network traffic data from the DARPA 1998 Intrusion Detection Evaluation project was processed for the "KDD Cup 1999 contest", held at the 5th ICKDDM ("International Conference on Knowledge Discovery and Data Mining"). The "KDD Cup" is an annual competition organized by the ACM Special Interest Group on Knowledge Discovery and Data Mining.

The "KDD Cup 1999 dataset" has two parts: a training dataset and a testing dataset. First, the training data is divided into five subsets to separate four types of attacks (Denial of Service (DoS), Remote to Local (R2L), User to Root (U2R), and Probe) from normal data. Fuzzy if-then rules are created by matching randomly generated fuzzy rules with the identified patterns in each category.

These rules are used to determine if the data shows normal or abnormal behavior. During testing, the test data is compared to the fuzzy rules to check if it represents an attack or normal activity.

The dataset includes various types of attacks broadly classified into the following four major types:

- a. **Denial of Service (DoS) Attacks:** These attacks aim to overwhelm memory resources, preventing legitimate users from accessing a machine or its services.
- b. **User to Root (U2R) Attacks:** In this type of attack, an intruder starts with a normal user account on the system and exploits vulnerabilities to gain root access.
- c. **Remote to User (R2L) Attacks:** These attacks occur when an external attacker, without an account on the target machine, exploits vulnerabilities to gain local user access.
- d. **Probes:** Probing attacks involve gathering information about a network to identify vulnerabilities or weaknesses.

Table 1. Summarizes the different types of attacks in each category

Category 1	Category 2	Category 3	Category 4
F1:duration	F10:hot	F23:count	F32: dst-host-count
F2:protocol-type	F11:num-failed-logins	F24:srv-count	F33:dst-host-srv-count
F3:service	F12:logged-in	F25:error-rate	F34:dst-host-same-srvrate
F4:flag	F13:num-compro-mised	F26:srv-serror-rate	F35:dst-host-diff-srvrate
F5:src-bytes	F14:root-shell	F27:error-rate	F36:dst-host-same-srcport-rate
F6:dst-bytes	F15:su-attempted	F28:srv-rerror-rate	F37:dst-host-srv-diffhost- rate
F7:land	F16:num-root	F29:same-srv-rate	F38:dst-host-serror-rate
F8:wrong-fragment	F17:num-file-creations	F30:diff-srv-rate	F39:dst-host-srv-serrorrate
F9:urgent	F18:num-shells	F31:srv-diff-host-rate	F40:dst-host-rerror-rate
	F19:num-access-files		F41:dst-host-srv-rerrorrate
	F20:num-outbound-cmds		
	F21:is-host-login		
	F22:is-guest-login		

Table 2. Summarizes the different types of attacks in each category

Sl. No.	Category	Attack Types
1	Denial of Service Attacks	Back, land, neptune, pod, smurf, teardrop
2	User to Root Attacks	Buffer_overflow, loadmodule, perl, rootkit,
3	Remote to Local Attacks	Ftp_write, guess_passwd, imap, multihop, phf, spy, warezclient, warezmaster
4	Probes	Satan, ipsweep, nmap, portsweep

4. PROPOSED MODEL

The current work develops a novel hybrid model using ANN and FUZZY (DLBADM). The different parts of this model are shown in Figure-1. The proposed system's different modules are

- a. Data Classifier
- b. Rules Generator(fuzzy)
- c. Fuzzy Module for Decision making
- d. Test data classifier

a) Data Classifier: We looked at the KDD Cup 1999 dataset, which has 41 features, including both continuous and symbolic data, as well as information about normal behavior and four types of attacks. Our method focuses on the continuous features because most of the important data in the dataset is continuous. So, we used only the 34 continuous features and removed the others. The dataset is then split into subsets based on the class marker. These marker describe normal data and four attack types: Remote to Local, DOS, , U2R, and Probing. These subsets are used to automatically create fuzzy rules, helping the system learn the rules better.

b) Rules Generator: Normally, professionals or individuals manually apply fuzzy rules to the fuzzy system after studying the behavior of intrusions. However, because our dataset has so many variables and input data, creating fuzzy rules manually is difficult. To solve this, we generate fuzzy rules using the FIS editor. Choosing the right features to create rules: In this step, we select the best features to decide if the data is normal or an attack. Since not all 34 features in the input data are effective at detecting intrusions, this step is important. We use a method called the deviation strategy to pick the right features. For our experiment, we selected 14 features, which are listed in Table 5.

Rule generation: The key features we identified are used to create rules based on the {max, min} deviation. We compare how these features behave in “normal” and “attacked” data to find common points. These points help us create both clear (definite) and unclear (indefinite) rules.

c) Fuzzy Module for Decision making: Here, we describe how we build a fuzzy inference system to find the correct test dataset. Fuzzy inference uses fuzzy logic to turn input data into an output. Fuzzy logic was created by Zadeh in the late 1960s [14, 15] and is based on Lukasiewicz's work on multivalued logic. In our case, we choose 14 features from the 34 inputs, and these features are used as both the input and output in the fuzzy inference system (FIS) with a defuzzification region.

d) Test data classifier: During testing, the test data from the KDD-Cup 99 dataset is input into the fuzzy logic system to get a fuzzy score. First, the 34 features of the test data are fed into a fuzzifier, which changes the numbers into words using a triangle membership function. The fuzzifier's output is then sent to the fuzzy inference engine, which checks it against a set of rules called the rule base. The rule base contains rules based on specific guidelines. The fuzzy inference engine gives an output that is either "Low" or "High." The final score from the engine is between 0 and 1, where ‘0’ means the data is completely normal, and ‘1’ means the data is completely attacked.

Training Data Set	
Normal	24950
DOS	24950
Probe	4106
R2L	76
u2R	41

Table 3. Record taken for training data

attrib

Testing Data Set	
Normal	25000
DOS	25000
Probe	4106
R2L	76
u2R	41

Table 4. Record taken for testing data

Sl no	Attribute Index	Selected Attributes	Range
1	F1	Duration	[0. 58329]
2	F5	src_bytes	[0.1.3 one billion]
3	F6	dst_bytes	[0. 1.3 one billion]
4	F8	wrong_fragment	[0.3]
5	F9	Urgent	[0,14]
6	F10	Hot	[0.101]
7	F11	num_failed_logins	[0.5]
8	F13	num_compromised	[0.9]
9	F16	num_root	[0.7468]
10	F17	num_file_creations	[0,100]
11	F18	num_shells	[0,5]
12	F19	num_access_files	[0.9]
13	F23	Count	[0.511]
14	F24	srv_count	[0.511]

Table 6. Confusion matrix

		Predicted Class	
		Positive Class	Negative Class
Actual Class	Positive Class	True Positive(TP)	False Negative(FN)
	Negative Class	False Positive(FP)	True Negative(TN)

Table 7. performance of the proposed model

		Metric		Proposed System	
				Training	Testing
PROBE	Precision			0.912532	0.912532
	Recall			0.37085	0.37085
	F-measure			0.5273556	0.5273556
	Accuracy			0.906218	0.909333
DOS	Precision			0.993553	0.993818
	Recall			0.90145	0.904156
	F-measure			0.9452625	0.9468725
	Accuracy			0.9488	0.949268
U2R	Precision			0.051958	0.051958
	Recall			0.190476	0.190476
	F-measure			0.0816327	0.0816327
	Accuracy			0.992112	0.993188
R2L	Precision			0.075959	0.075959
	Recall			0.155744	0.155744
	F-measure			0.1021287	0.1021287
	Accuracy			0.991586	0.991909
NORMAL	Precision			0.828479	0.829328
	Recall			0.99426	0.994375
	F-measure			0.9037654	0.9043803
	Accuracy			0.910852	0.903119

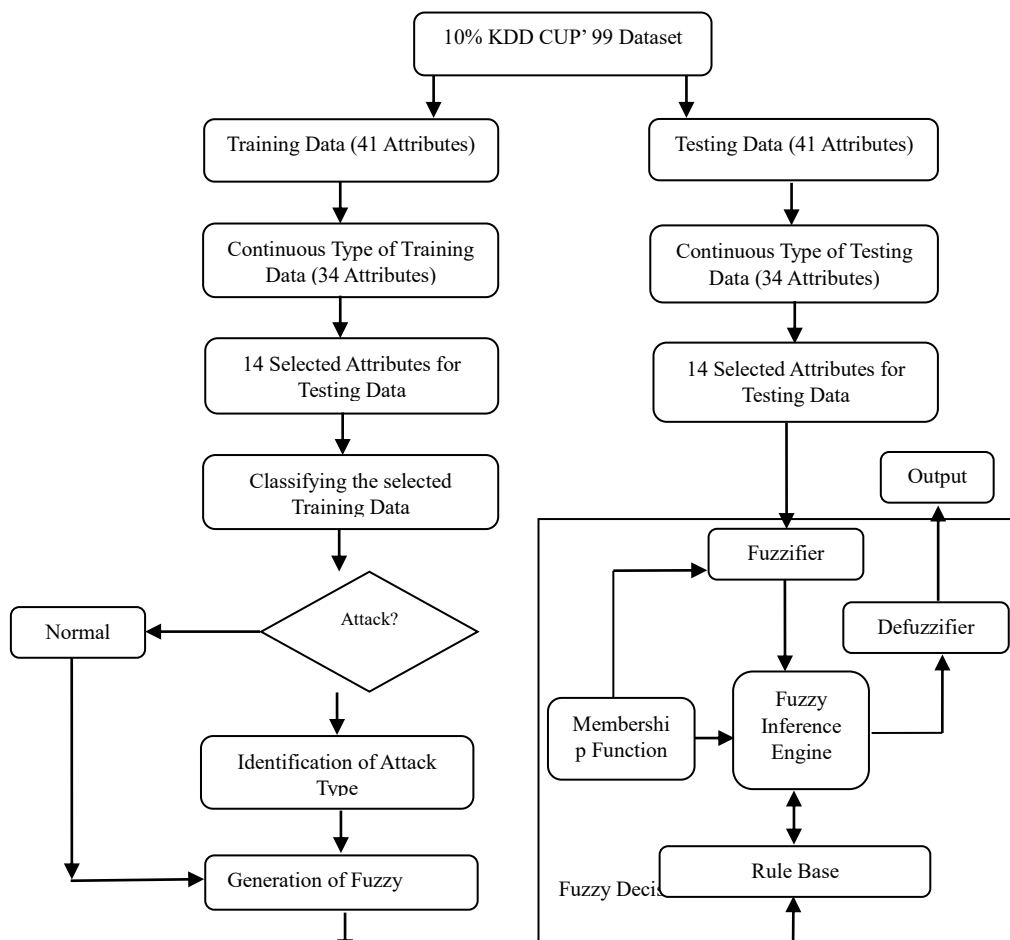

Figure 1. The training dataset includes normal data

5. RESULT STUDY

Here we look at the results and performance of the proposed model. We used MATLAB to implement the system, and its performance is measured using Precision, Recall, and Measure. For the experiment, we used the KDD Cup 99 dataset [13], which is widely used to test intrusion detection systems. Since the KDD Cup 99 dataset is large, it's hard to run the system on all of it. So, we used only 10% of the dataset for both testing and training. The number of records used for testing and training is shown in tables 3 and 4.

The training dataset includes normal data and four types of attacks (DoS, U2R, R2L, and Probe). The system uses this data to identify the important features for creating rules. The selected features are listed in Table 5. The system then generates both definite and indefinite rules using a fuzzy rule learning method. After that, it creates fuzzy rules from the definite ones. During the testing phase, the system uses the test data to decide whether the input is normal or an attack. The system's accuracy is measured based on the results. To calculate the accuracy, we use Precision, Recall, and F-measure, which help evaluate how well the system

detects unusual activities. High recall is important, but it should not reduce precision. F-measure combines both recall and precision into one score.

Precision = True positive / (True positive(TP)+False Positive(FP))

Recall = True positive / (True positive(TP)+False negative(FN))

F-measure = $[(\alpha^2 + 1) (\text{Precision} \cdot \text{Recall})] / [(\alpha^2 \cdot \text{Precision} + \text{Recall})]$ Where $\alpha = 1$

Overall Accuracy = (True positive(TP)+True negative(TN)) / (True positive(TP) + True negative(TN)+False negative(FN)+False Positive(FP))

These are computed using the confusion matrix in Table 6.

During testing, the evaluation measures are computed for both training and testing datasets. The outcomes obtained for all “attacks” and “normal” data are shown in Table 7, which includes the KDD Cup 99 dataset. Examining the results reveals that the recommended strategy outperforms the others overall and attains an accuracy of more than 90% for all types of attacks.

6. Conclusion

This study demonstrated successfully the application of ANN and FUZZY techniques in intrusion detection. It introduced a model for identifying intrusions using the anomaly detection approach. To enhance the accuracy of attack detection, a fuzzy decision module was developed based on the fuzzy inference method. An effective set of fuzzy rules was formulated, which proved to be highly efficient for detecting intrusions in computer networks. The process began with the generation of definite rules, which were then converted into fuzzy rules through fuzzification. These fuzzy rules were input into the fuzzy system to classify the testing data. The developed model was evaluated using the KDD Cup 99 dataset, and experimental results confirmed its effectiveness in detecting various types of intrusions in computer networks.

References

- [1] Yao, J. T., S.L. Zhao, and L.V. Saxton, “A Study On Fuzzy Intrusion Detection”, In Proceedings of the Data Mining, Intrusion Detection, Information Assurance, And Data Networks Security, SPIE, Vol. 5812, pp. 23-30, Orlando, Florida, USA, 2005.
- [2] S. Zhong, T. Khoshgoftar, N. Seliya, “Clustering-based network intrusion detection”, In Intl. Journal of Reliability, Quality and Safety, Vol. 14, pp. 169-187, No. 2, 2007
- [3] Pakkurthi Srinivasu, P.S. Avadhani, Vishal Korimilli, Prudhvi Ravipati, “Approaches and Data Processing Techniques for Intrusion Detection Systems”, Vol. 9, No. 12, pp. 181-186, 2009.
- [4] T.F. Lunt, A. Tamaru, F. Gilham, R. Jagannatham, C. Jalali, P.G. Neumann, H.S. Javitz, A. Valdes, T.D. Garvey, “A Real-time Intrusion Detection Expert System (IDES),” Computer Science Laboratory, SRI International, Menlo Park, CA, USA, Final Technical Report, February 1992.
- [5] Shah, K., Dave, N., Chavan, S., Mukherjee, S., Abraham, A. and Sanyal S. Adaptive neuro-fuzzy intrusion detection system. IEEE International Conference on Information Technology: Coding and Computing (ITCC'04), vol. 1. USA: IEEE Computer Society; 2004; 70–74.
- [6] Anderson, D., Frivold, T. and Valdes, A. Next-generation intrusion detection expert system (NIDES): A summary Technical Report SRI-CSL-95-07, Computer Science Laboratory, SRI International, May 1995.

- [7] Stephen F. Owens, Reuven R. Levary, "An adaptive expert system approach for intrusion detection", *International Journal of Security and Networks*, Vol: 1, No: 3/4, pp: 206-217, 2006.
- [8] O. Adetunmbi Adebayo, Zhiwei Shi, Zhongzhi Shi, Olumide S. Adewale, "Network Anomalous Intrusion Detection using Fuzzy-Bayes", *IFIP International Federation for Information Processing*, Vol: 228, pp: 525-530, 2007.
- [9] Bharanidharan Shanmugam, Norbik Bashah Idris, "Improved Intrusion Detection System Using Fuzzy Logic for Detecting Anomaly and Misuse Type of Attacks", in *Proceedings of the International Conference of Soft Computing and Pattern Recognition*, pp: 212-217, 2009.
- [10] Jaiganesh, V., Sumathi, P. and Mangayarkarasi, S., "An Analysis of Intrusion Detection System using back propagation neural network", *IEEE Computer Society Publication*, 2013.
- [11] Mahbod Tavallaee, Ebrahim Bagheri, Wei Lu and Ali A. Ghorbani, "A detailed analysis of the KDD CUP 99 data set", in *Proceedings of the Second IEEE international conference on Computational intelligence for security and defense applications*, pp. 53-58, Ottawa, Ontario, Canada, 2009.
- [12] <http://www.ll.mit.edu/mission/communications/ist/corpora/ideval/data/1998data.html>
- [13] <http://www.sigkdd.org/kddcup/index.php?section=1999&method=data>
- [14] www.cse.unr.edu/~bebis/CS365/Papers/FuzzyLogic.pdf, <http://www.aptronix.com/fide/> ...
[.edu/~fishwick/paper/paper.html](http://www.fishwick.com/paper/paper.html).
- [15] Zadeh, L.A., "Fuzzy sets", *Information and control*, vol.8, pp. 338-353, 1965.

Study on Surface Drainage system of the Capital City of Bhubaneswar

Chinmayananda Sahoo¹, Joygopal Jena², Anshu Raj³, Kalyani S. Singh⁴

¹Department of Civil Engineering, GITA Autonomous College, Bhubaneswar,

²Departments of Civil Engineering, GITA Autonomous College, Bhubaneswar,

³Department of Civil Engineering, GITA Autonomous College, Bhubaneswar,

⁴Deartment of Civil Engineering, GITA Autonomous College, Bhubaneswar,

{cnsahoo2016@gmail.com, jenajoygopal@gmail.com, anshurajvp7689@gmail.com, kalyani5ceb@gita.edu.in}

Corresponding author: cnsahoo2016@gmail.com

Revised on 13th July 2025 and Accepted on 28 Oct 2025

Abstract

Bhubaneswar, celebrated for its rich heritage and historical prominence as the Temple City and the capital of Odisha, has earned the distinction of being designated as India's top Smart City. Over the past two decades, the city has experienced rapid urbanization, marked by a significant population influx and increased commercial activities, placing immense strain on existing infrastructure, including roads, surface drainage, and sewerage systems etc. Focusing on the surface and storm water drainage system, urban watersheds are divided into small catchments by streets, highways, and channels, with most drainage designs catering to catchments of 100 to 200 acres. To prioritize traffic safety in urban areas, street drainage systems are designed to ensure the rapid disposal of storm water. This study explores the hydrologic aspects of small catchments, the challenges in planning, design, and maintenance of surface drainage systems, the improvements implemented at various stages, and proposed measures to enhance the system further.

Keywords: Surface drainage, Urban Catchment, Water logging, Bhubaneswar

1. Introduction

Urbanization in India has led to significant challenges, particularly in cities like Bhubaneswar, where rapid growth has strained existing infrastructure. Urban drainage systems, crucial for managing wastewater and storm water, face unique challenges in accommodating expanding populations and unplanned urban development. The interaction between human activities and the natural water cycle highlights the importance of effective drainage systems. In urban areas, wastewater generated from daily use and industrial activities and surplus surface water from rainfall must be managed efficiently. However, the infrastructure in many Indian cities,

including Bhubaneswar, was not designed to handle the projected population growth and increased urban activity. The absence of a comprehensive drainage plan has exacerbated issues like flooding and waterlogging. Bhubaneswar city has witnessed rapid urbanization over the past two decades, with its population reaching nearly one million due to growth in educational institutions, industries, and employment opportunities. This surge has increased pressure on essential services such as roads, water supply, sewerage, and drainage systems.

Despite its designation as India's top Smart City, Bhubaneswar grapples with inadequate drainage infrastructure. Natural drains within the city often lie on government or private land, and the city lacks underground drainage systems or a cohesive surface drainage network. Encroachment by slum dwellers and unregulated construction has further obstructed storm water drains, while a lack of maintenance and garbage disposal in drains exacerbates the issue. Approximately 35% of the city has access to basic sewerage systems, leaving the remainder reliant on septic tanks or direct discharge of untreated sewage into natural drainage channels. The unplanned expansion of Bhubaneswar has also blocked natural drainage paths on private land, complicating efforts to develop a functional drainage network.

The city's storm water drainage spans 340 km, but roadside drains are often repurposed for commercial activities or covered with RCC slabs, which serve as footpaths. Addressing the drainage challenges in Bhubaneswar will require tailored solutions that consider local topography, natural water flow, soil conditions, and rainfall patterns. As Bhubaneswar aims to solidify its status as a Smart City, prioritizing the development of an efficient and sustainable drainage system is imperative to meet the needs of its growing population and urban landscape.

2. Topographical Characteristics of the City

The city is geographically situated in the east-coast plains of India at 22.270° N latitude and 85.840° E longitude. The area covered by the city proper is 135 square kilometers, while its suburban expanse is approximately 256.38 square kilometers, encompassing 101 revenue villages. The average elevation of the city is 45 meters above mean sea level (MSL), with the general elevation varying between 7 meters and 75 meters. This natural gradient, sloping from north to south and west to east, supports efficient drainage. The city is surrounded by tributaries of the Mahanadi River, with the Daya River to the south and the Kuakhai River to the east, both playing a vital role in its water management system. The western part of the city is characterized by undulating terrain interspersed with valleys, making it particularly conducive to natural drainage.

This region includes 10 distinct natural drainage channels that carry surface runoff combined with urban effluents. Of these, Drain No. 1 discharges into the Kuakhai River, while the remaining nine drains flow into the GanguaNallah, which ultimately connects to the Daya River. The natural topography ensures that these drains follow a west-to-east alignment, facilitating the smooth discharge of stormwater and wastewater. The city's drainage network is

further enhanced by its natural slopes, which provide a fair gradient, making the system inherently compatible with safe water discharge.

The drainage system traverses various prominent locations, including EkamraKanan, JayadevVihar, Gajapati Nagar, Sainik School, VaniVihar, the western region of Mancheshwar, AcharyaVihar, the ISKCON Temple area, Aiginia, Jagamara, and Pokhariput etc. These areas are critical nodes within the city's drainage framework, acting as conduits for managing water flow during heavy rainfall and urban runoff. Despite the challenges posed by urbanization, the city's natural features offer a robust foundation for water management. The valleys and slopes in the western parts effectively channel excess water, ensuring that the urban drainage system functions efficiently.

The integration of natural and urban drainage systems is essential for mitigating flooding and managing water efficiently, particularly as urban expansion continues. By utilizing its natural gradient and aligning its drainage paths with the existing topography, the city can optimize the flow of stormwater and effluents. Figure 1 provides a detailed depiction of the city's drainage system, illustrating the alignment of the natural drains and their role in connecting to larger water bodies. Overall, the geographical features of the city play a pivotal role in shaping its drainage infrastructure, ensuring a sustainable approach to managing water flow in this rapidly urbanizing region.

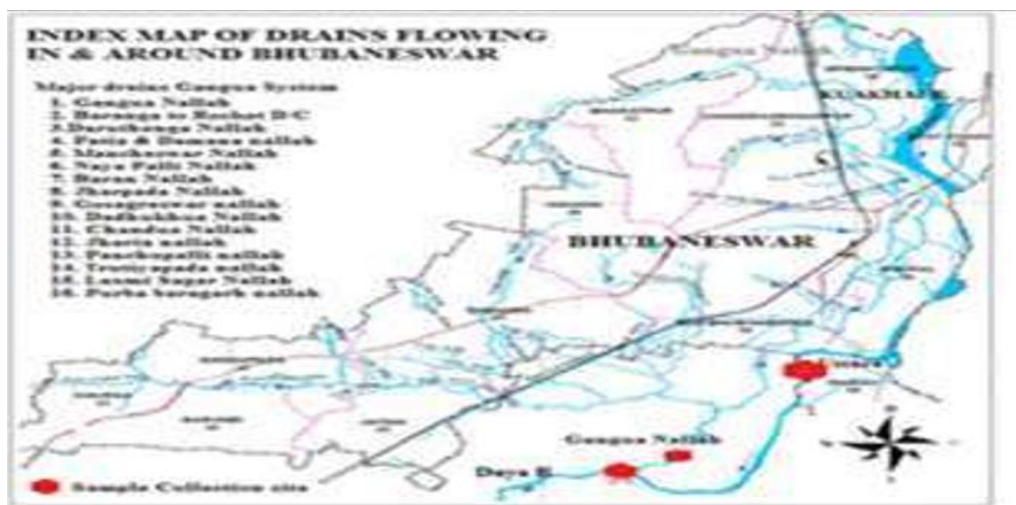

Fig.1. Bhubaneswar City Drainage system

3. Hydrology and Drainage Infrastructure

Bhubaneswar situated in the tropical climatic zone, experiences three distinct seasons: summer, winter, and monsoon. The south-east monsoon winds bring rainfall from June to October, contributing significantly to the city's average annual rainfall of approximately 1,487 mm, which falls over 72 rainy days. The rainy season in Bhubaneswar lasts from the third week of June to the first week of November, and the average monsoon rainfall from June to September is 1,105 mm. Peak rainfall occurs in the third week of August. Urban areas like Bhubaneswar

face heightened vulnerability to loss of life and property during heavy rainfall events due to the high concentration of population and economic activities. This heightened risk necessitates specialized approaches to the design of stormwater drainage systems, as urban runoff characteristics differ significantly from those of rural areas. Factors such as reduced infiltration due to impervious surfaces, increased runoff velocity, and potential blockage of drainage paths make urban stormwater management a critical challenge. The Central Public Health and Environmental Engineering Organization (CPHEEO), under the Ministry of Urban Development, Government of India, addressed sewer design extensively in its "Manual on Sewerage" (1993) but devoted limited attention to storm drainage design. The manual has given the growing urbanization and its associated risks; there is an urgent need for more comprehensive guidelines tailored to urban stormwater management.

Designing efficient urban stormwater drainage systems requires an analysis of rainfall data to understand intensity and duration patterns. Long-term rainfall records from automatic rain gauges are instrumental in developing intensity-duration-frequency (IDF) curves, which are crucial for the design of stormwater drains. These curves represent the relationship between rainfall intensity, duration, and frequency, enabling engineers to predict and design for extreme rainfall events. Mathematical expressions derived from IDF analysis help determine runoff volumes and peak flows, guiding the design of drainage infrastructure to handle projected loads efficiently. The consideration of factors such as catchment characteristics, urban topography, and climate change projections further enhances the reliability of drainage systems. As urbanization continues, integrating advanced hydrological modelling techniques with sustainable design practices will ensure resilient and adaptive drainage solutions, minimizing the adverse impacts of urban flooding. The following two equations are widely applied in hydrological studies:

1. $I = a / (t^n)$
2. $I = a / (t + b)$

In these equations:

- I represent the rainfall intensity (mm/hr),
- t is the storm duration (minutes), and
- a, b, and n are constants derived from rainfall data analysis.

The relationship between rainfall intensity (I) and time of concentration (t_c) is vital in hydrological studies, particularly in the design and analysis of urban drainage systems. By plotting available data on rainfall intensity and time, the intensity values for any given duration can be determined. Typically, rainfall intensity decreases with increasing storm duration, a pattern that is analysed using a log-log plot of intensity (i) versus time (t). The line of best fit through these data points enables the calculation of coefficients 'a' and 'n', which describe the mathematical relationship between intensity and duration. Using these parameters, a curve is generated on an ordinary graph scale, providing a clear depiction of the variation in rainfall intensity over time. This curve is crucial for deriving Intensity-Duration-Frequency (IDF)

relationships, which are fundamental tools in hydrological modelling. These IDF curves facilitate a systematic approach to analysing the temporal distribution of rainfall and its implications for infrastructure design.

The IDF curve is particularly significant for evaluating the annual variation in rainfall and determining the rainfall intensity corresponding to different return periods. This analysis allows engineers to predict the frequency and magnitude of storms and design drainage systems capable of safely managing storm water runoff. For instance, in the presented case, the city drainage system was designed to accommodate a rainfall intensity of 28.88 mm/hr, ensuring adequate capacity to handle storm water and mitigate flooding risks. This intensity value represents a critical threshold derived from the IDF analysis for a specific return period. By incorporating these scientifically derived parameters, urban planners and engineers can ensure the robustness of drainage systems, minimizing the adverse impacts of extreme rainfall events on urban infrastructure and communities. The rainfall records of Bhubaneswar and the IDF curve are presented respectively in FIG 2 and Fig 3.

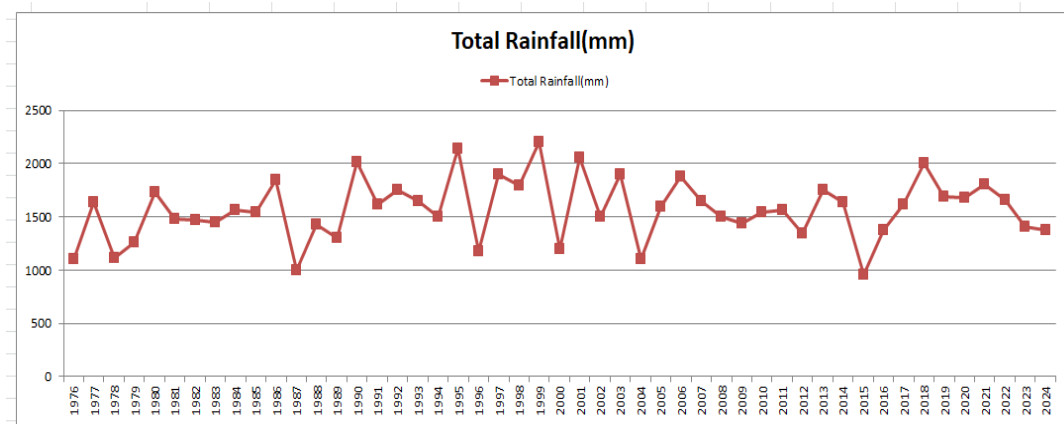

Figure 2. Annual Rainfall Variations in Bhubaneswar

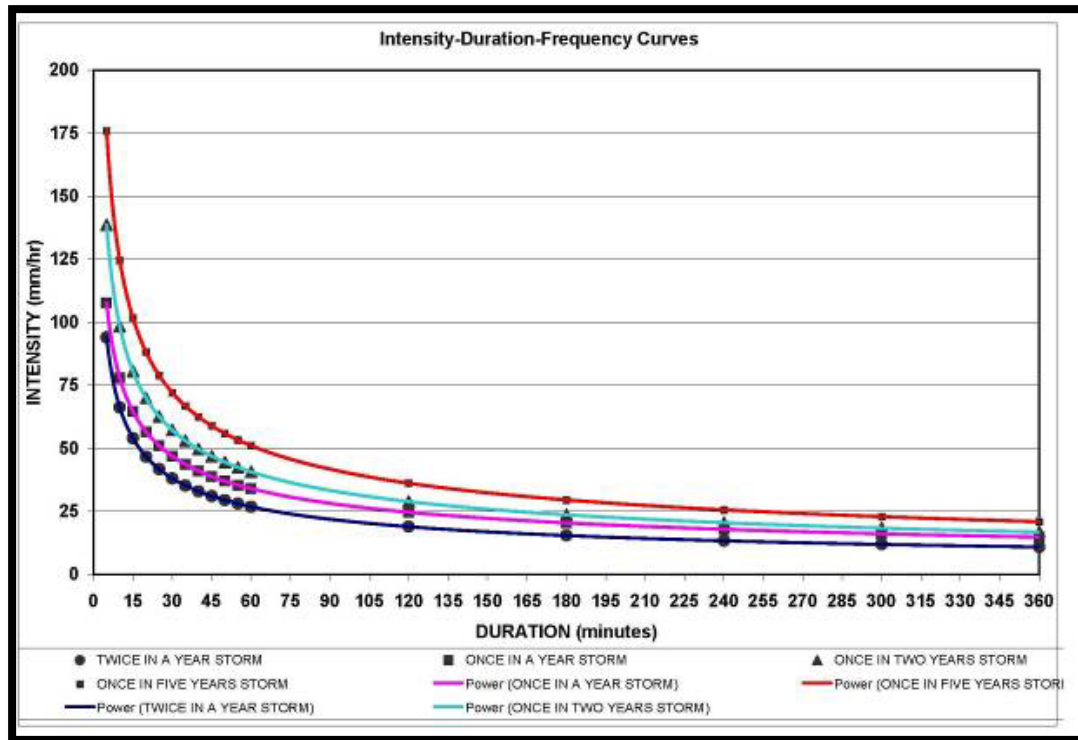

Figure 3. Intensity-Duration-Frequency Curves

The Rational Method is the most commonly used approach for designing drainage systems. It is based on several assumptions:

- Peak flow occurs when the entire watershed contributes to the runoff.
- Rainfall intensity remains constant across the entire drainage area.
- Rainfall intensity is uniform over a time duration equal to the time of concentration.
- The frequency of the computed peak flow matches the frequency of the rainfall intensity, e.g., a 10-year rainfall event produces a 10-year peak flow.
- The runoff coefficient remains consistent for storms of all recurrence intervals.

The Rational formula is expressed as:

$$Q=10\times C\times i\times A$$

Where:

- Q = runoff (m³/hr)
- C = coefficient of runoff
- i = rainfall intensity (mm/hr)
- A = drainage area (hectares)

It's important to note that the sewer system does not convey all the precipitation; instead, Q represents the actual runoff reaching the sewer system. Drains must have an unobstructed

drainage plain to manage peak runoff during peak precipitation. This drainage plain should remain free from encroachments, regardless of land use.

While the Rational Method is widely employed for drainage design, it has certain limitations:

- a. It is most effective for estimating peak runoff, inlet design, and stormwater drainage systems for areas under 200 acres (80 hectares).
- b. Accurate assessment of the drainage area is crucial for reliable results.
- c. The method cannot account for detention or reservoir routing flows.

4. Existing Drainage Network Assessment

Two decades ago, Bhubaneswar did not face significant drainage issues, as natural drains efficiently managed water flow across both government and private lands. However, the government did not acquire private lands for developing drainage infrastructure, leading to problems over time. The current drainage congestion is largely due to encroachments on natural drains by private landowners and illegal constructions. In some areas, the drain beds are higher than the road levels, causing roads to act as drains during heavy rains. City planning authorities exercise minimal control over government establishments, public sector units, and large private sector entities regarding land use, focusing only on FAR, front, rear, and side offsets, with no regulations to ensure appropriate plinth levels. Maintenance of drains is fragmented among multiple government authorities, and enforcement remains weak. Efforts are often limited to studies, reports, or piecemeal solutions, failing to address the root causes of the problem effectively.

Bhubaneswar has been selected for integrated urban development under the Jawaharlal Nehru National Urban Renewal Mission (JNNURM), with a strong focus on improving stormwater drainage infrastructure as a key funding priority. The City Development Plan (CDP), approved by the Government of India, serves as the foundation for preparing a Master Plan to enhance the stormwater drainage system of Odisha's capital city. To support this initiative, the Bhubaneswar Development Authority (BDA) has collaborated with Water and Power Consultancy Services India Ltd. (WAPCOS) to develop a Comprehensive Drainage Plan aimed at addressing the city's drainage challenges. The agencies currently responsible for the execution and maintenance of the drainage system are outlined in Table 1.

Table 1. Agencies Responsible for Maintenance of the drains inside the City

Sl. no	Category of Drains	Agency responsible for its Management
1	Natural Drains	Water Resources Department, Govt. of Odisha
2	Drains inside jurisdiction of BMC	Bhubaneswar Municipal Corporation (BMC)
3	Road side drains along N. H.	National Highway Authority of India
4	Road side drains along PWD roads	Bhubaneswar Municipal Corporation (BMC)
5	Drains in areas developed by BDA	Bhubaneswar Development Authority (BDA)
6	Institutional Area like university etc	The concerned institutions

Since the inception of Bhubaneswar as the capital city, insufficient attention has been paid to incorporating drainage as a civic amenity in town planning. No designated space was reserved for this essential purpose. Natural drains within the city boundaries and its suburban areas exist partly on government land and partly on private land, but the city lacks underground drainage infrastructure. Additionally, there is no comprehensive surface drainage system to manage water flow effectively. Over the years, unplanned urban growth has progressively restricted or blocked natural drainage paths, particularly on private land. This has created significant challenges in establishing an efficient drainage system with a clear, continuous pathway, making it an arduous task in the current context.

Though Bhubaneswar has got recognition as Smart City in the country, now faces the urgent need for a well-developed surface drainage system to support its urban aspirations. Confronted by the recurring problem of drainage congestion, various state authorities have made several attempts in the past to develop a comprehensive drainage plan for the city. However, none of these efforts have led to the successful implementation of a complete scheme. Localized improvements have been made periodically on a piecemeal basis, which fail to address the issue holistically. Presently, a detailed study for comprehensive drainage planning has been undertaken by the Department of Water Resources (DoWR) under the JNNURM scheme, with funding from the Housing and Urban Development (H&UD) Department.

Given the complexity and sensitivity of the drainage congestion issue, its resolution has been entrusted to the Housing and Urban Development Department, Government of Odisha. The government has expressed a strong commitment to resolving this challenge and has decided to establish an exclusive Urban Drainage Organization under the administrative control of the Bhubaneswar Municipal Corporation (BMC). This initiative aims to address the issue more effectively by eliminating the current dual administrative approach, where natural drains are partially managed by the DoWR and the remainder by the BMC. Centralizing responsibility under the proposed Urban Drainage Organization is expected to streamline operations and ensure greater diligence in handling the city's drainage concerns. Table 2 provides a detailed list of the proposed schemes aimed at improving the drainage system of Bhubaneswar city.

Table 2. List of Schemes Proposed for Improvement of Drainage System

Sl no	Various schemes	Agency preparing the scheme	Year
1	Drainage Development Scheme	BDA, through Water and Power Consulting Services India Ltd. (WAPCOS).	1995
2	Report on Storm Water Drainage Project of Bhubaneswar City	Department of Water Resources Department, Govt. of Odisha (DoWR)	1996
3	Special Assistance for Project Formulation (SAPROF) Report	Govt. of Orissa	1996

4	Draft Interim Development Plan, South City, Bhubaneswar	BDA, Prepared by IL&FS-IDC Ltd	1997
5	City Development Plan (CDP) for Bhubaneswar City	Prepared under JNNURM Scheme	2010
6	JNNURM Scheme	DoWR through Meinhardt Singapore Pvt. Ltd.	2013

5. Current Execution Framework

The latest planning outlines the division of the entire area into 18 small drainage catchment basins, including ten prominent natural drains. The drainage network is categorized into four classifications: Natural, Primary, Secondary, and Tertiary. The existing natural channels, already operational, are classified as Naturals. Constructed or proposed tributary drains that discharge into these natural drains are Primary drains, which, in turn, receive inflows from feeder drains classified as Secondary. These Secondary drains are fed by a network of Tertiary drains that handle local and roadside catchment areas. The proposed drainage plan aims to establish a comprehensive network encompassing 10 natural drains spanning 65.87 km, Primary drains for 321.57 km, Secondary drains for 357.91 km, and Tertiary drains for 358.23 km, totaling 1037.71 km in length. This figure excludes the main Gangua drain, which extends 37 km and is subject to a separate proposal under consideration. Of the proposed network, approximately 340 km of the system across various classifications already exists, constructed incrementally over time and currently in operation. The implementation of this extensive drainage project is planned in two phases. For the parent carrying drain, Gangua, a dedicated development plan has been prepared, taking into account the acquisition of private land required for the project. This initiative reflects a strategic approach to enhance the region's drainage infrastructure systematically.

6. Enhancement Opportunities

1. **Comprehensive Drainage Planning:** Avoid piecemeal approaches by adopting integrated and holistic strategies.
2. **Regulating Plinth Levels:** Introduce a 'General Plinth Level' criterion for zoning, alongside existing FAR and setback norms, to prevent waterlogging due to unrestricted plinth variations. Ensure accountability of building plan approval authorities.
3. **Uniform Urban Development Guidelines:** Develop a standardized manual for urban water drainage systems, addressing unregulated suburban expansions that exacerbate drainage congestion.
4. **Water Body Management:** Enhance the inlet and outlet systems of the city's 60 recognized water bodies, interconnecting them wherever feasible to alleviate encroachment and improve water flow management.
5. **Mandatory Rooftop Water Harvesting:** Implement mandatory rooftop water harvesting in all buildings to recharge groundwater and reduce surface runoff during the rainy season, mitigating drainage issues.
6. **Underground Drainage Solutions:** Introduce underground drainage systems in specific locations to address encroachment and streamline water flow.

7. **Public Awareness and Enforcement:** Promote cleanliness awareness campaigns and enforce strict penalties for violations to ensure a cleaner and more effective drainage system.

These measures aim to create a sustainable, efficient, and resilient drainage infrastructure while addressing urban development challenges.

7. Conclusion

The Government of Odisha, in collaboration with the Water Resources Department and the Bhubaneswar Development Authority, has consistently recognized the importance of establishing a robust stormwater drainage infrastructure for the city. Despite these efforts, none of the proposed schemes have reached a level of detail sufficient for implementation. The outlined proposals emphasize the critical need for an effective stormwater drainage system to address current and future challenges. Therefore, it is imperative to prioritize and undertake immediate steps toward the development and execution of a comprehensive stormwater drainage system to ensure sustainable urban management and improved quality of life for the city's population.

References:

- [1.] Chapter 5, Project Report, Functional Plan on Drainage for NCR
- [2.] Comprehensive Master Plan and Detailed Project Report for Storm Water Drainage System of Bhubaneswar city under JNNURM Scheme of Govt. of India
- [3.] Dash, A. (2016), Analytical Study of Rainfall Probability at Bhubaneswar. *International Journal of Applied and Pure Science and Agriculture (IJAPSA)*, Volume 02, Issue 06, e-ISSN: 2394-5532, p-ISSN: 2394-823X.
- [4.] Drainage Manual, Central Public Health and Environmental Engineering Organization (CPHEEO), 1993
- [5.] Gupta, Kapil (2006), "The drainage systems of Indian Cities", *Water lines*, Vol 23, No 4, April Pp 22-24
- [6.] Guo, James C.Y. (2000). "Storm Hydrographs for Small Catchments," *IWRA International J. of Water*, Vol 25, No. 3, September, Pp 1-10
- [7.] Hosseinzadeh, S.R. (2005) "The effect of urbanization on the natural drainage patterns and the increase of urban floods: case study Metropolis of Mashhad - Iran" *WIT Transaction on Ecology and the Environment*, Vol 84, WIT Press
- [8.] Jena S.(2014)," Integrated study and quality analysis of surface drainage and sewer water for Bhubaneswar Municipal Corporation, India" SSN: 2321-0869, Volume-2, Issue-10, October 2014
- [9.] Lohani, T.K, Samant, K.C, Patnaik, R.S and Dash, K.P (2013), Improvement of Drainage System in Cuttack-Bhubaneswar Twin City, Odisha. *Journal of Water Resource and Hydraulic Engineering*, Vol. 2 Iss. 3, PP. 104-115.
- [10.] Ram Kumar Kushwah, AvinashBajpai and Suman Malik, 2011, Wastewater Quality Studies of Influent and Effluent Water at Municipal Wastewater Treatment plant, Bhopal (India), *International Journal of Chemical, Environmental and Pharmaceutical Research*, Vol. 2 (2-3), 131-134
- [11.] Rout, N. R. (2008), "Slum Growth in Bhubaneswar: A Problem or Solution?" *ITPI Journal*, 5: 4,59 – 64.

- [12.] Sandipan Ghosh and Tithy Maji, 2011, An Environmental Assessment of Urban Drainage, Sewage and Solid Waste Management in Bardhaman Municipality, West Bengal, International Journal of Environmental Sciences, Volume 2 (1), pp. 93-105
- [13.] Torres, A.S., Vojinovic, Z., and Price, R. (2014) "Assessing Rehabilitation Strategies of Urban Drainage Systems Based on Future Scenarios of Urbanization" 11th International Conference on Hydro informatics, HIC 2014, New York City, USA

Coordination in Twin Circuit Protection for Under-Reach Scenarios without Residual Current Contributions

Bibhudatta Paikaray¹, Priyadarsini Pradhan², Rabinarayan Rout³, Sahasranshu Das⁴, Abinash Mahapatra⁵, Kashyap Kumar⁶

¹ Department of Electrical Engineering, GITA Autonomous College, Bhubaneswar, Odisha, India,
Email: bibhupaikaray1979@gmail.com

² Department of Electrical Engineering, GITA Autonomous College, Bhubaneswar, Odisha, India,
Email: priyadarsini81in@gmail.com

³ Department of Electrical Engineering, GITA Autonomous College, Bhubaneswar, Odisha, India,
Email: erabinarayan@gmail.com

⁴ Department of Electrical Engineering, GITA Autonomous College, Bhubaneswar, Odisha, India,
Email: sahasranshu.das7@gmail.com

⁵ Department of Electrical Engineering, GITA Autonomous College, Bhubaneswar, Odisha, India
Email: abinashmahapatra0205@gmail.com

⁶ Department of Electrical Engineering, GITA Autonomous College, Bhubaneswar, Odisha,
Email: kashyapkumar652@gmail.com

Corresponding author: bibhupaikaray1979@gmail.com

Revised on 23th Aug 2025 and Accepted on 22 Oct 2025

Abstract

Particularly when 1- \emptyset to earth faults occur, mutual coupling in transmission lines poses serious difficulties for precise fault isolation and identification. In parallel lines with the same right-of-way, interaction in zero-sequence circuits might affect long-distance measurements of apparent impedance. This impact causes relays at one of the ends of the malfunctioned wire to overrun and the opposite end to underreach. [1] These discrepancies can lead to inaccurate fault sensing and even false tripping of adjacent healthy lines, causing unnecessary system interruptions. One primary issue arises from zero-sequence voltage inversion due to the coupling effects between the zero-sequence networks of parallel lines. This phenomenon complicates the accurate identification of ground faults, potentially compromising the overall reliability of the protection scheme. The impact of this is particularly critical in twin circuit configurations, where the proximity of parallel circuits amplifies mutual coupling effects. The study provides analytical formulas for the effective sequence impedances of twin circuit lines in order to address these issues. These expressions provide foundation for understanding and mitigating mutual coupling impacts in real-time protection schemes. Furthermore, a microprocessor-based algorithm is proposed to estimate fault distances and correct under-reach errors.

Keywords— Measurement, power transmission, microprocessor applications, Distance, protective

1. Introduction

For electric power transmission lines—especially those with terminals spread widely apart—distance relays are the most popular, dependable, and selective protection devices available. Two or more 3- \emptyset transmitting circuits located on the same tower or adjacent towers within the same right-of-way make up MCTLs (multi-circuit transmission lines). In recent years, right-of-way limits have compelled the installation of multi-circuit poles to accommodate additional circuits or the jamming of extra lines into existing corridors. The performance of a distance relay is impacted by two primary factors that complicate reach setting: (i) Parallel transmission circuits that are mutually coupled (ii) The fault impedance characteristics are uncertain. Transmission problems arise when parallel lines travelling via an identical corridor or on the same tower mutually pair. The mutual induction among parallel current-carrying cables complicates the setup of unidirectional earth fault relays. The reciprocal coupling is only found in zero-sequence networks of transposed parallel circuits. In the event of a phase-to-ground fault in a single line, the zero-sequence voltage of a single, healthy parallel line and its zero-sequence network changes, going from a negative to a positive value. As a result, fault current is led by zero-sequence voltage instead of typical voltage and current relationship that voltage-polarized ground relays demand. For proper polarization, these relays anticipate, fault current will lead voltage by angle 90° . False tripping of healthy line is caused by polarization errors, which contribute to inaccurate fault direction and distance determination. This failure is contingent upon the extent of the induced.

Relaying.

This study investigates how mutual coupling effects in twin-circuit parallel lines might introduce ambiguity into the measurement of apparent impedance. It presents a microprocessor-based, non-iterative algorithm that can be incorporated into simple distance relaying systems. The proposed method doesn't involve residue current measurements from a parallel circuit for fault distance determination and zero-sequence compensation implementation. Additionally, the plan can be used in situations where transmission circuits share a similar transmission corridor over a predetermined distance but do not terminate at the same substation.

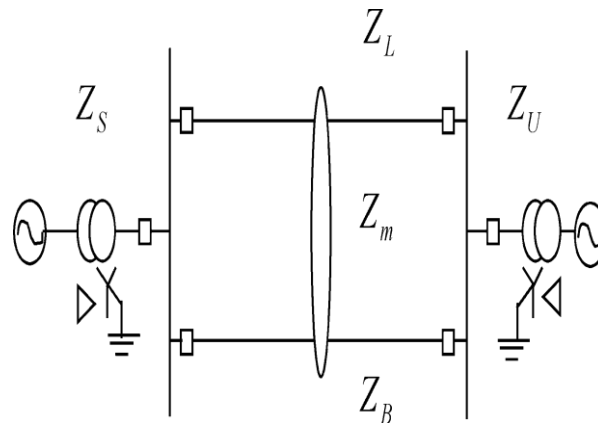

Fig.1. Parallel line (Twin-circuit)

2. Operational Impedance and Fault Identification

If self-impedance is represented by Z_s of a phase and mutual impedance by Z_p of same circuit two phases, these are fundamental impedance parameters of one transmission line.

The basic sequence impedances of line can then be expressed as, $Z_L^0 = z_s + 2z_p, Z_L^+ = z_s - z_p$ When

a Type-1 network's lines exhibit inter-circuit mutual coupling (as in Fig.(1)), effective sequence impedances [Appendix, Equations] of the lines are calculated as follows:

$$\begin{aligned} Z^0 &= -k_1 h^2 + k_2 h + k_3, Z^+ = -k_4 h^2 + k_5 h + k_6 \\ Z^- &= -k_4 h^2 + k_5 h + k_6 \end{aligned} \quad (1)$$

Per unit is used to describe the fault's fractional distance from the sending end. Parallel transmission lines with identical busses at both ends are known as type-1 networks. The mutually connected lines in Type-2 networks occupy the same transmission corridor for a significant distance, but they share a common node at one end. Type-3 networks are made up of mutually linked roadways that do not stop at common buses at either end but share the right-of-way for a significant distance. Coupling between elements in networks with both positive and negative periods should generally be ignored for transposed lines, and only coupling in systems with zero sequence should be taken into account. Considering the mutual impedance among two parallel line phases, the zero-sequence connection between the phases of the healthy and defective circuits can be expressed as [2]. When zero sequence interconnection is considered into account in a Type-1 network, the effective 0-sequence impedance is given by [Appendix A]

$$Z^0 = \frac{-k_7 h^3 + k_8 h^2 + k_9 h + k_{10}}{k_{11} + k_{12} h} \quad (2)$$

Effective sequence impedances in a Type-1 network change with fault location, as shown in Figure 2. It highlights the significant variations in effective zero-sequence impedance patterns between scenarios that include and neglect zero-sequence mutual coupling. The solid with dotted lines represent different source impedance values, demonstrating the impact of these variations on the impedance characteristics.

3. Fault Localization and Sequence Current Metrics

At a relaying point for the phase-to-ground faulty line, the proportion of zero-sequence current with negative-sequence current can be written simply [Appendix A]

$$K_R^{02} = \frac{I_R^0}{I_R^-} = \frac{(C_1 + hC_2)C_3}{C_4 C_5} \quad (3)$$

Similarly, the proportion of positive sequences current compared with zero sequence current at the relay point can be found. Figure 3 shows the connection between fault location and sequence current ratios in a Type-1 network. It highlights the large difference in the sensitivity of these ratios to fault location when the sequence of zero mutual coupling is considered and when it is not. The analysis emphasizes the influence of zero sequence mutual coupling on fault detection sensitivity, showing how its inclusion substantially modifies the response patterns.

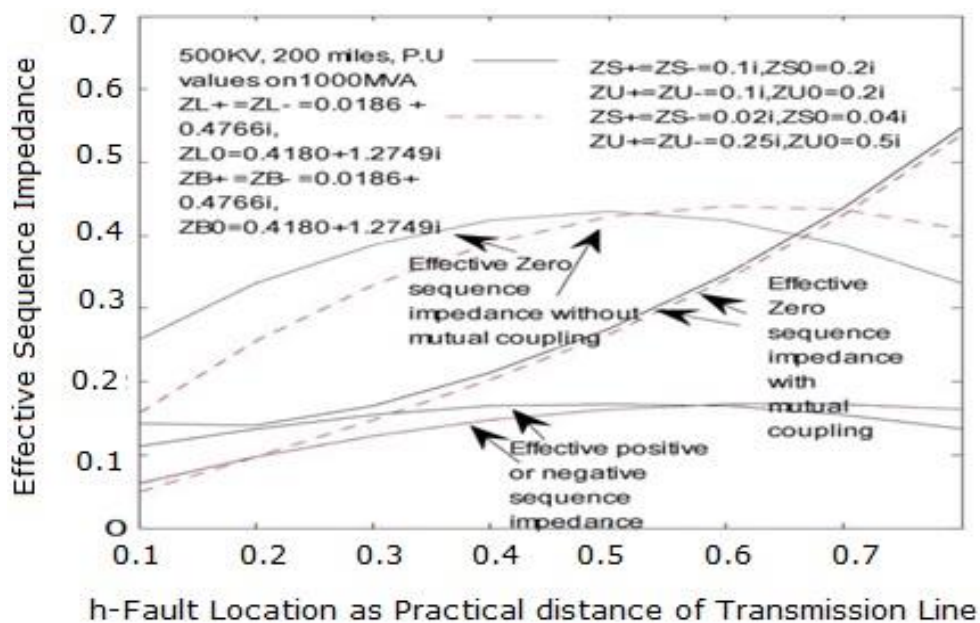

Fig 2. Fault location with effective sequence impedance

4. Fault Location Estimation

One important factor in figuring up the compensation to fix the positive sequence impedance of relay detected and solve its under reach on the transmission line. Using K_R^{02} the expression in Equation (3), by deriving the sending end fault distance as [Appendix A]

$$h = \frac{K_R^{02} A - B}{K_R^{02} C - D} \tag{4}$$

This expression eliminates the need for the measurements of residual current of the parallel circuit and remains effective even when the link failure of data communication in a Type-1 network.

5. Ground Fault Compensation

Three relay components make up a distance relay, which is placed at both end of transmission line. Based on impedance setting of its own zone, each element is set up to monitor a predetermined "zone" or section of the line. Furthermore, a particular operating time delay is allocated to every zone element. The component of Zone-1, however, is designed to operate instantaneously without any time delay, providing immediate protection for faults occurring within the closest section of the transmission line.

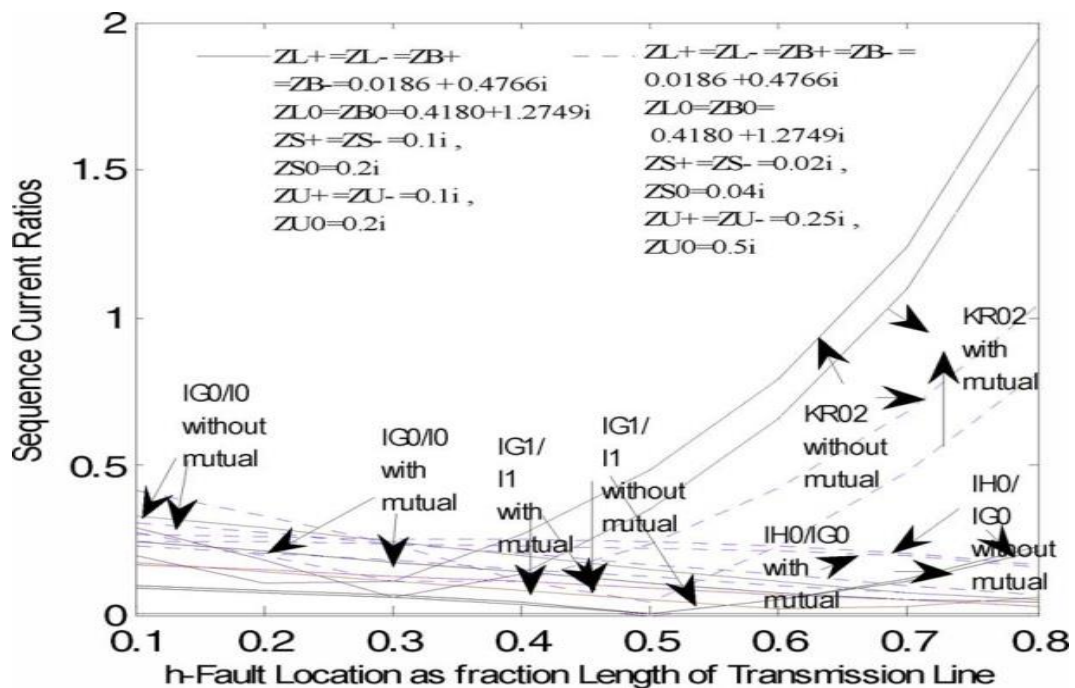

Fig. 3 Fault location and sequence current ratios

In essence, the voltage drop brought on by the fault current moving between the fault point and relay is reflected in the voltage measurement of the relay location. Ratio of voltage drop to current passing through the line is known as the impedance of that line. So, the relay monitors

perceived impedance or apparent impedance, up to the failure point. When (Z_{app}) apparent impedance is measured by voltage and current at relay position, falls within the specified impedance range for that zone and remains within this range for a period longer than the time delay setting of that zone, distance relay activates the relevant zone element. However, in reality, voltage drop brought on by mutual impedance at the relay position is also included in the voltage measurement. (Z_{app}).

6. Conclusion

The effectiveness of a twin-circuit line protection system is influenced by several factors, including the fault location, system configuration, most significantly, the degree of zero-sequence mutual coupling of two circuits. Furthermore, the flow of sequence currents in defective line is influenced by healthy line switching state. The ratio of sequence currents, which is essential for precise fault detection, is determined by these elements taken together. By predicting the sequence impedance, the suggested microprocessor-based algorithm for a simple distance relaying technique makes it possible to calculate the fault distance in real time. This method also helps evaluate the extent of under-reach, significantly reducing the risk of relaying failures due to under-reach conditions. The technique is a strong and dependable method for fault detection in twin-circuit systems because it functions well without requiring residual current input from the parallel line.

Appendix- A

Twin Circuit Parallel Overhead Line Effective Sequence Impedances: Type-1 Network

Avoiding Inter-Circuit Bilateral Coupling: The parallel organization of the comparable circuits remains the same if all inter-circuit mutual interaction among the positive, negative, and zero-sequence devices is ignored; the only difference is the numerical values of the parts of the circuit. The following impedance values are determined for the lower part of that equivalent circuit depending on the similar circuit depicted in Figure 4 following delta-star transformation.

Index takes the symbols +ve,-ve or Zero, based on sequence equivalent circuit.

Zero Sequence Impedance:

$$Z^0 = Z_l^0 + \frac{Z_M^0 Z_N^0}{Z_M^0 + Z_N^0}$$

The parallel system's zero-sequence impedance, when considering the lines fundamental zero-sequence impedance and end source impedances, is:

Positive Sequence Impedance:

$$Z^0 = \frac{Z_S^0 Z_U^0}{Z_S^0 + Z_B^0 + Z_U^0} + \frac{\left\{ h Z_L^0 + \frac{Z_S^0 Z_B^0}{Z_S^0 + Z_B^0 + Z_U^0} \right\} \times \left\{ (1-h) Z_L^0 + \frac{Z_B^0 Z_U^0}{Z_S^0 + Z_B^0 + Z_U^0} \right\}}{Z_L^0 + \frac{Z_S^0 Z_B^0 + Z_B^0 Z_U^0}{Z_S^0 + Z_B^0 + Z_U^0}}$$

After algebraic simplifications

$$Z^0 = - \frac{(Z_L^0)^2 Z_S^0 + Z_B^0 + Z_U^0}{Z_L^0 (Z_S^0 + Z_B^0 + Z_U^0) + Z_S^0 Z_B^0 + Z_B^0 Z_U^0} h^2 + \frac{(Z_L^0)^2 (Z_S^0 + Z_B^0 + Z_U^0) + Z_L^0 + (Z_B^0 Z_U^0 + Z_S^0 Z_B^0)}{Z_L^0 (Z_S^0 + Z_B^0 + Z_U^0) + Z_S^0 Z_B^0 + Z_B^0 Z_U^0} h + \frac{Z_S^0 Z_B^0 Z_U^0 + Z_L^0 (Z_S^0 Z_B^0 + Z_S^0 Z_U^0)}{Z_L^0 (Z_S^0 + Z_B^0 + Z_U^0) + Z_S^0 Z_B^0 + Z_B^0 Z_U^0}$$

$$Z^0 = -k_1 h^2 + k_2 h + k_3$$

$$Z^+ = Z_I^+ + \frac{Z_M^+ Z_N^+}{Z_M^+ + Z_N^+}$$

The fundamental positive-sequence impedance of lines and source impedances at the ends determine the parallel circuit's positive-sequence impedance:

$$Z^+ = \frac{Z_S^+ Z_U^+}{Z_S^+ + Z_B^+ + Z_U^+} + \frac{\left(h Z_I^+ + \frac{Z_S^+ Z_B^+}{Z_S^+ + Z_B^+ + Z_U^+} \right) \times \left((1-h) Z_I^+ + \frac{Z_B^+ Z_U^+}{Z_S^+ + Z_B^+ + Z_U^+} \right)}{Z_I^+ + \frac{Z_S^+ Z_B^+ + Z_B^+ Z_U^+}{Z_S^+ + Z_B^+ + Z_U^+}}$$

After algebraic simplifications

$$\begin{aligned}
 Z^+ &= -\frac{(Z_L^+)^2 (Z_S^+ + Z_B^+ + Z_U^+)}{Z_L^+ (Z_S^+ + Z_B^+ + Z_U^+) + Z_S^+ Z_B^+ + Z_B^+ Z_U^+} h^2 \\
 &+ \frac{(Z_L^+)^2 (Z_S^+ + Z_B^+ + Z_U^+) + Z_L^+ + (Z_B^+ Z_U^+ + Z_S^+ Z_B^+)}{Z_L^+ (Z_S^+ + Z_B^+ + Z_U^+) + Z_S^+ Z_B^+ + Z_B^+ Z_U^+} h \\
 &+ \frac{Z_S^+ Z_B^+ Z_U^+ + Z_L^+ (Z_S^+ Z_B^+ + Z_S^+ Z_U^+)}{Z_L^+ (Z_S^+ + Z_B^+ + Z_U^+) + Z_S^+ Z_B^+ + Z_B^+ Z_U^+}
 \end{aligned}$$

Negative Sequence Impedance: Following a similar approach

$$Z^- = Z_l^- + (Z_M^- Z_N^- / Z_M^- + Z_N^-).$$

A formula resembling that to the positive-sequence obstruction is obtained after substituting values in terms of the basic negative-sequence impedances of the lines and performing the required algebraic simplifications. After that, the positive-sequence numbers are converted to their matching negative-sequence values. The negative-sequence impedance of the parallel circuit is then ascertained

by:

$$Z^- = -k_4 h^2 + k_5 h + k_6$$

The parallel line combination's positive and negative sequence equivalent circuits are identical to those without inter-circuit mutual coupling. But as Fig. 4 shows, the zero-sequence equivalent circuit is changed. Following the delta-star transformation, the lower portion elements' corresponding values are:

$$\begin{aligned}
 Z_k^0 &= \frac{(Z_B^0 - Z_C^0)(Z_U^0 + (1-h)Z_C^0)}{Z_S^0 + Z_B^0 + Z_U^0} \\
 Z_l^0 &= \frac{(Z_S^0 + hZ_C^0)(Z_B^0 - Z_C^0)}{Z_S^0 + Z_B^0 + Z_U^0} \\
 Z_M^0 &= Z_j^0 + h(Z_L^0 - Z_C^0) \\
 Z_N^0 &= Z_k^0 + (1-h)(Z_L^0 - Z_C^0)
 \end{aligned}$$

Zero Sequence Impedance:

$$Z^0 = Z_l^0 + \frac{Z_M^0 Z_N^0}{Z_M^0 + Z_N^0}$$

After algebraic simplification and substitution of different lines and end sources' fundamental zero-sequence impedance values, the result is:

$$Z^0 = \frac{-k_7 h^3 + k_8 h^2 + k_9 h + k_{10}}{k_{11} + k_{12} h}$$

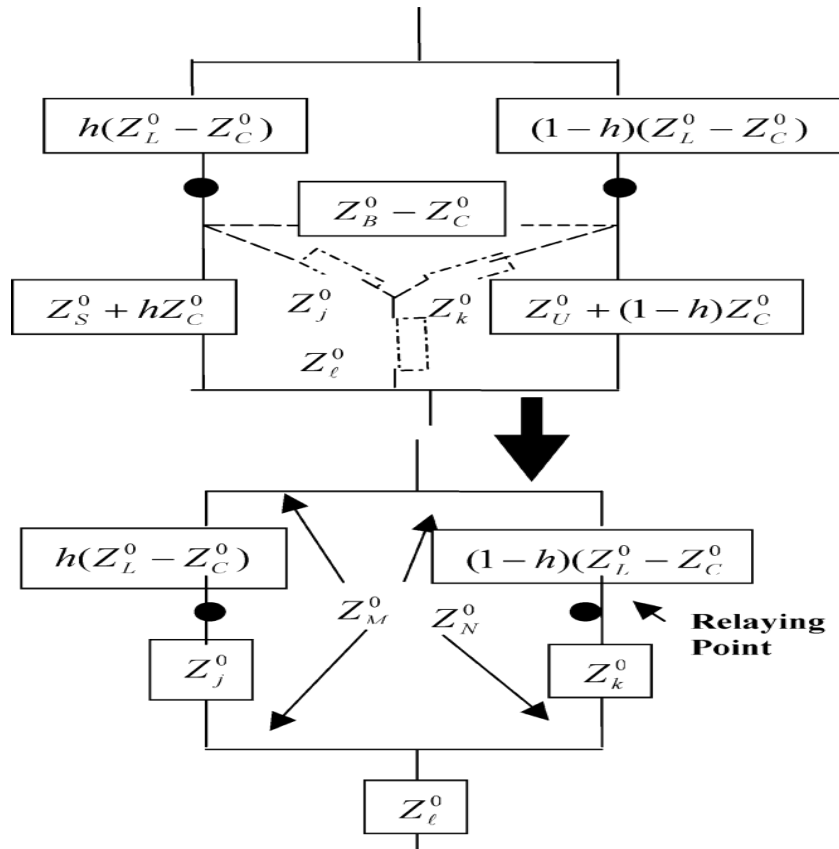

Fig 4. Equivalent Circuit and Inter-Circuit Zero-Sequence Mutual Coupling

Where,

$$k_7 = (Z_C^0)^3 (Z_S^0 - Z_B^0)$$

$$k_8 = \left\{ (Z_C^0)^2 Z_U^0 + (Z_C^0)^3 - (Z_C^0)^2 Z_S^0 \right\} (Z_S^0 - Z_B^0)$$

$$- (Z_C^0)^2 \left\{ (Z_S^0)^2 - Z_S^0 Z_C^0 + Z_B^0 Z_U^0 \right.$$

$$\left. + Z_B^0 Z_C^0 - Z_U^0 Z_C^0 - (Z_C^0)^2 \right\}$$

$$- \left\{ (Z_C^0)^2 + 2Z_C^0 (Z_B^0 - Z_C^0) \right\} (Z_L^0 - Z_C^0) (Z_S^0 + Z_B^0 + Z_U^0)$$

$$- (Z_B^0 - Z_C^0)^2 (Z_C^0)^2 + (Z_L^0 - Z_C^0)^2 (Z_S^0 + Z_B^0 + Z_U^0)$$

$$\begin{aligned}
 k_9 &= Z_S^0 Z_U^0 Z_C^0 (Z_S^0 - Z_B^0) + \{Z_U^0 Z_C^0 + (Z_C^0)^2 - Z_S^0 Z_C^0\} \\
 &\times \{(Z_S^0)^2 - Z_S^0 Z_C^0 + Z_B^0 Z_U^0 + Z_B^0 Z_C^0 - Z_U^0 Z_C^0 - (Z_C^0)^2\} \\
 &+ \{Z_C^0 Z_U^0 + (Z_C^0)^2 - Z_S^0 Z_C^0\} (Z_L^0 - Z_C^0) (Z_S^0 + Z_B^0 + Z_U^0) \\
 &+ (Z_C^0)^2 Z_S^0 (Z_S^0 - Z_B^0) \\
 &+ (Z_B^0 - Z_C^0)^2 \{Z_C^0 Z_U^0 + (Z_C^0)^2 - Z_S^0 Z_C^0\} \\
 &+ (Z_L^0 - Z_C^0)^2 (Z_S^0 + Z_B^0 + Z_U^0)^2 \\
 &+ (Z_B^0 - Z_C^0) (Z_L^0 - Z_C^0) (Z_U^0 + Z_C^0) \\
 \\
 k_{10} &= Z_S^0 (Z_U^0 + Z_C^0) \{(Z_S^0)^2 - Z_S^0 Z_C^0 \\
 &+ Z_B^0 Z_U^0 + Z_B^0 Z_C^0 - Z_U^0 Z_C^0 - (Z_C^0)^2\} \\
 &+ Z_S^0 (Z_U^0 + Z_B^0) (Z_L^0 - Z_C^0) (Z_S^0 + Z_B^0 + Z_U^0) \\
 &+ Z_S^0 (Z_B^0 - Z_C^0)^2 (Z_U^0 + Z_C^0) \\
 \\
 k_{11} &= \{(Z_S^0)^2 - 2Z_S^0 Z_C^0 - 2Z_U^0 Z_C^0 - (Z_C^0)^2 \\
 &+ Z_B^0 Z_U^0 + Z_L^0 Z_S^0 + Z_L^0 Z_B^0 + Z_L^0 Z_U^0\} \\
 &\times (Z_S^0 + Z_B^0 + Z_U^0) \\
 \\
 k_{12} &= (Z_S^0)^2 Z_C^0 - (Z_B^0)^2 Z_C^0 + Z_C^0 (Z_S^0 - Z_B^0) Z_U^0
 \end{aligned}$$

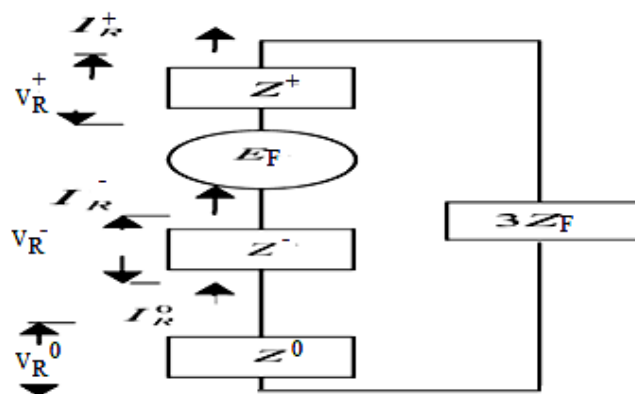

Fig 5. Equivalent circuit (SLG)

References

- [1] Mukerjee, R. N., & Abdullah, M. F. B., "Under-reach correction in twin circuits without residual current input from the parallel line," *IEEE Trans. Power Del.*, vol. 23, no. 3, pp. 1359-1365, 2008.
- [2] Anderson, P. M., *Power System Protection*, ser. IEEE Press Power Engineering, New York: McGraw-Hill, 1999.
- [3] Jongepier, A. G., & Van der Sluis, L., "Adaptive distance protection of a double-circuit line," *IEEE Trans. Power Del.*, vol. 9, no. 3, pp. 1289–1297, Jul. 1994.
- [4] *Protective Relays Application Guide*, St. Leonard Works, 3rd ed., Stafford, U.K., GEC Alsthom T&D Protection & Control Limited, 1995.
- [5] Grainger, J. J., & Stevenson Jr., W. D., *Power System Analysis*, New York: McGraw-Hill, 1994.
- [6] Zhao, X., Liu, Y., & Wu, F., "Distance protection for parallel transmission lines with mutual coupling consideration," *IEEE Trans. Power Del.*, vol. 31, no. 2, pp. 650-658, 2016.
- [7] Zhang, H., & Xu, L., "A novel approach to solve the under-reach problem in distance protection of parallel lines," *IEEE Trans. Power Syst.*, vol. 32, no. 3, pp. 2022-2031, 2017.
- [8] Makhija, A., & Kulkarni, R., "Enhanced distance protection for parallel transmission lines under mutual coupling and fault impedance conditions," *Electric Power Syst. Res.*, vol. 172, pp. 77-85, 2019.
- [9] Pal, B. C., & Paserba, J., "Distance relaying for parallel transmission lines under mutual coupling and unbalanced fault conditions," *IEEE Trans. Power Del.*, vol. 21, no. 1, pp. 470-477, 2006.
- [10] Babaei, E., & Aghaei, J., "A novel fault detection algorithm for twin-circuit transmission lines with zero-sequence mutual coupling," *IEEE Trans. Power Syst.*, vol. 28, no. 3, pp. 2515-2523, 2013.
- [11] Yao, Y., & Luo, W., "Improved distance protection algorithm for parallel transmission lines without parallel line residual current input," *Int. J. Electr. Power Energy Syst.*, vol. 115, p. 105374, 2020.

Evolutionary Algorithm for Network on Chip Architecture: A Survey

V.Singh¹, K.P.Swain², A.S.Das³, P.K.Bal⁴, Subhashree Choudhury⁵

¹Department of CSE, GITA Autonomous College, Bhubaneswar, India ²Chief Technical Officer, J Systems and Control, Cuttack, India ³Department of EEE, ITER, SOA Deemed to be University, India

*Corresponding Author's Email id: vikas_cse@gita.edu.in

Revised on 29th Aug 2025 and Accepted on 27 Oct 2025

Abstract:

Continuous demand for high performance embedded systems driving the System on Chip (SoC) market in an uphill trend. High performance requires more processing power and

capacity. To achieve more processing power from a single chip, SoC designers are putting more Processing Elements (PE) onto a single silicon substrate. Putting a greater number of PEs on a single substrate requires very high-speed bus and deadlock-free scheduling which are getting more and more complicated day by day. To address this situation, Network on a Chip architecture is adopted in recent years. Network on Chip (NoC) in contrast with SoC utilizes an on-chip interconnection network. On-chip interconnection networks facilitate the connection of a greater number of PEs. The On-chip network routing facilitates deadlock-free scheduling and parallel processing. One of the important aspects of NoC is Optimal Mapping. Optimally mapping the participating cores means low bandwidth requirement, low latency hence greater throughput. Optimization of communication bandwidth cost for On-Chip Networks” or “Bandwidth cost optimization for Network on Chip is the prime factor for consideration In this regard, this review article discusses in detail the advantages of NoC over SoC technology, recent issues in NoC, types of graphs, mapping of NoC through numerous evolutionary algorithm, NoC design process and NoC platform. An attempt has been made to comprehensively discuss every aspect of NoC regarding various optimization techniques for the process of mapping.

Keywords: Network on Chip (NoC), System on Chip (SoC), Mapping, Optimization, Processing Elements (PE), Scheduling.

1. Introduction

cores. Inefficient core communication leads to an underperforming subsystem, which in turn results in an overall inefficient system. To enhance the efficiency of multicore chips, the System-on-Chip (SoC) concept was introduced. However, SoC faces scalability challenges due to its bus-based architecture. The Network-on-Chip (NoC) concept was developed to overcome these limitations and address SoC's shortcomings.

System on Chip: A System-on-Chip (SoC) is a specialized subsystem within an embedded system or a larger system. It is an Integrated Circuit (IC) that combines multiple components or all elements of a computing or electronic system into a single chip. An SoC may incorporate digital, analog, mixed-signal, and radio frequency (RF) functionalities. This description closely resembles that of microcontrollers. In contrast microcontrollers are very small purpose systems, whereas SoCs are meant for huge applications like running desktop OS like Microsoft Windows or Linux; for example AMD Geode, Texas Instruments' Citara etc. The SoC name itself suggests large integration of electronics into a single chip. Increased integration results in reduced cost of manufacture and smaller size. A typical SoC may contain

- A Microcontroller, Microprocessor, DSP core(s). some SoC may have more than one processing elements they are called MP SoC
- So memory blocks including ROM, RAM, EPROM and Flash memory
- Clock generators or PLL
- Peripherals like power-on reset, real-time timers, counters etc.
- External interfaces like USB, I2C, SPI, USART etc.

- Analog interfaces ADCs and DACs
- Power conditioner sand regulators.

Cores in SoC are connected by industry-standard buses like Advanced Microcontroller Bus Architecture (AMBA™) of ARM Holdings or through DMA channels avoiding dependencies on processing elements. SoC uses the bus to communicate between different cores. It uses the master-slave concept for bus arbitration. With the increase in the number of cores, the SoC bus gets overloaded and clogged. An overloaded bus gives rise to inefficient performance, huge latency and degraded throughput.

Network on Chip: Network-on-Chip (NoC) is a modern trend in the industry, replacing traditional bus-based communication with network-based communication between cores within a subsystem. NoC serves as an on-chip communication framework that connects various Intellectual Property (IP) components of the subsystem. It employs industry-standard High-Performance Computing (HPC) interconnection topologies to address scalability issues. However, non-optimal placement of nodes within the network can negatively impact overall performance. Optimal node positioning is determined by the communication patterns, with highly interactive nodes ideally placed as neighbors to enhance efficiency.

It is already mentioned that NoC has many cores which communicate among themselves over a network. For effective communication, routers are implemented in NoC. Routing of data packets between any 2 cores is done by on-chip routers. On-chip routers are registers and buffers implemented on the same chip as part of the infrastructure. The effective functioning of routers relies on routing protocol.

The entire article has been categorized into the following sections. Section 2 highlights the research gap in NoC design. In Section 3 various types of graphs are discussed in detail. Section 4 throws light on the process of mapping. In Section 5 a detailed study concerning the Noc platform basics, NoC design process and various optimization techniques for NoC mapping has been projected. The conclusion from the entire review of literature is presented in Section 6.

2. Research Issues in NoC Design

NoC is a recent trend. Several groups from industries to educational institutions are conducting research in different dimensions. These dimensions can be classified into the following categories.

Communication infrastructure: It is already stated NoC is a non-chip interconnection network. Hence it should have a communication infrastructure. This encompasses aspects such as network topology, router design, buffer optimization, link architecture, clocking mechanisms, floor planning, and layout configuration.

Communication paradigm: The NoC infrastructure functions as a packet-switched network, requiring the definition of strategies for routing policies, switching mechanisms, congestion control, power and thermal management, fault tolerance, and reliability.

Evaluation framework: A properly designed NoC should have minimum latency, energy/power consumption, and bandwidth of the network. For validation and simulation of an

NoC evaluation framework plays an important role.

Application mapping: Application mapping is the fourth important aspect in the NoC design process. Application mapping means placing different interacting tasks (nodes) in suitable positions, such that, overall performance is best. Application mapping influences the overall performance of the NoC. There exists a lot of work on all aspects of NoC design except for application mapping. Hence application mapping has scope for more work.

3. Graphs

Task graph: A task graph is a fully connected directed graph. Each node in the task graph is a single unique task that needs to be performed for the successful run of the whole application. Task graph $G(V,E)$ is a directed graph where V represents the set of all nodes present in the graph and E represents the set of all edges. Each edge in the task graph represents a communication between the cores connected by that edge. And the weight of the edge represents the communication bandwidth requirement between nodes connected by the edge[1].

Mathematically represented as $G(V,E) \forall v_i \in$

Fig 1. shows various types of Task Graphs.

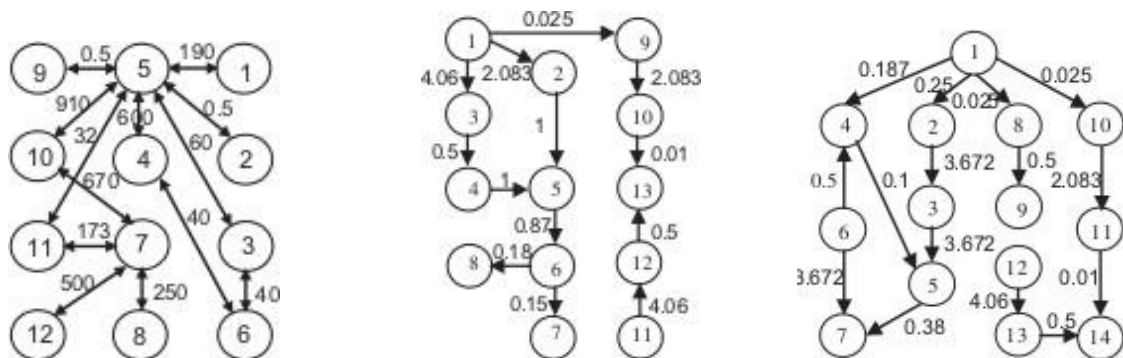
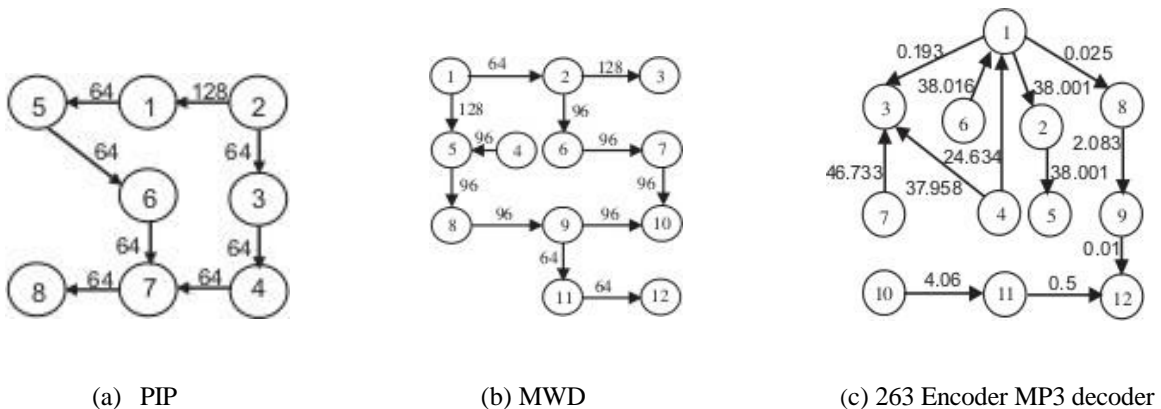

(d) MPEG4

(e) MP3 encoder MP3 decoder

(f) 263 decoder Mp3 decoder

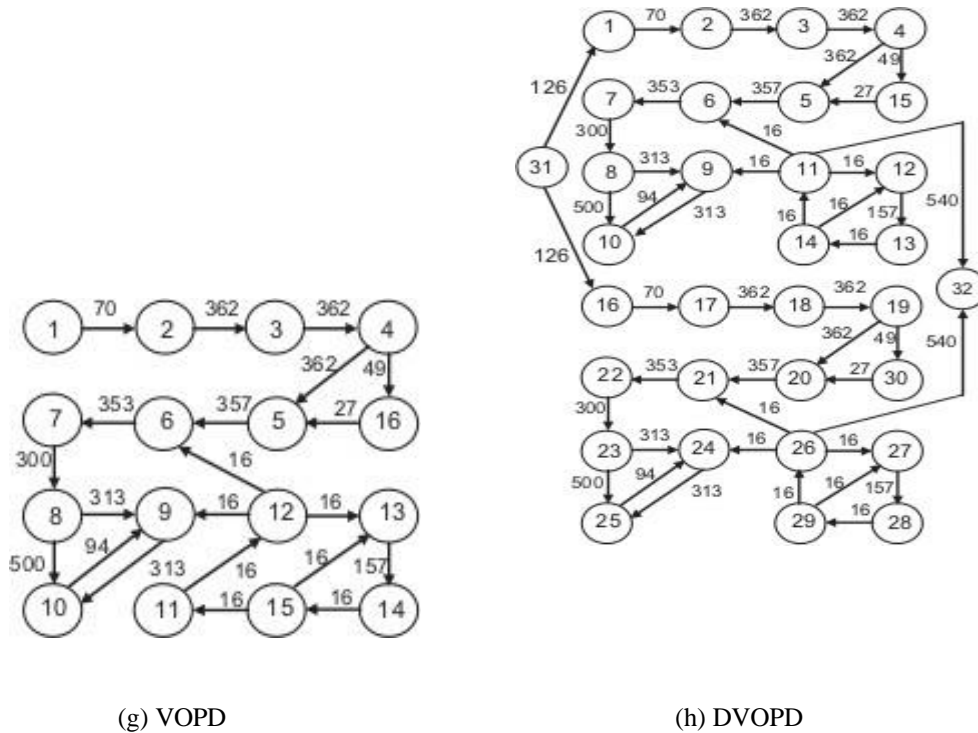

Fig 1. Task graphs 2

Topology graph: Topology represents a scheme for interconnection. A topology graph is a graph that represents a topology using graph theory terminology. A topology graph is a fully connected graph representing target topology and architecture. Every node in the topology graph represents a router. Depending on the architecture and topology chosen routers can be the same or different. In 2Dmesh topology, all routers are the same. Routers in tree-based topology are classified in root, stem and leaf routers. A topology graph is represented by $T(U,F) \forall u_i \in U$ and $f_{i,j} \in F \forall i \neq j$ where U is the set of all vertices in the graph and F is the set of all edges in the topology graph. $f_{i,j}$ is termed as bandwidth $bw_{i,j}$ which is the bandwidth needed between node u_i and u_j [1].

4. Mapping

Application mapping is the process of mapping a task graph to a given high-performance topology. Such that, every node in the task graph is mapped to a unique node in the topology graph. A mapping between $G(V,E)$ and $T(U,F)$ is defined as $map(v_i) = u_j \forall v_i \in V, \exists u_j \in U$ and $|V| \leq |U|$. In other words, a map of a core v_i to router u_i is possible when the number of cores is less or equal to the number of routers 2Dmesh or number of leaf connectors in a tree-based topology graph. The quality of mapping is defined by the total communication cost of the NoC.

The communication flow between 2 core scan be defined as $dk, k = 1,2,3,...,|E|$. If v_i is mapped to u_i and v_j mapped to u_j then the weight of $e_{i,j} \in E$ is called comm. i,j . Set of all

commodities $D = \{d_k | d_k = \text{comm } i, j \text{ for } k=1,2,3,\dots, |E| \text{ where } i, j \in E\}$ Maximum band width requirement between 2 routers u_i and u_j is given by

$$X_{i,j}^k = \begin{cases} \text{value}(d_k) & \text{if } f_{i,j} \in \text{path} \\ 0 & \text{otherwise} \end{cases} \quad (1)$$

Constraint or Objective: The mapping of task graph GGG to topology graph TTT should minimize the total bandwidth consumption across all cores. This means that cores with high communication activity should be positioned closer to one another.

Mathematically

$$\text{cost} = \sum_{i=1}^{|E|} bw_{i,j} \times \text{distance}(u_i, u_j)$$

Should be minimum (2)

Where $\text{distance}(u_i, u_j)$ is the function that returns the distance between source and sink routers. The unit of distance is hops for mesh and related architecture and cycle count for tree-based architecture.

5. NoC Mapping

The literature survey focuses on different mapping techniques. More attention is given to transformative heuristics such as Ant colony-based optimization (ACO), Particle swarm optimization (PSO) and GA based optimization. Any work related to the mapping of NoC cores cannot be complete without mentioning “Bandwidth Constrained Mapping of Cores onto NoC Architectures” by Srinivasan Murali, Giovanni De Micheli [1]. This research paper introduced NMAP, a constructive heuristic with an iterative improvement algorithm. NMAP is considered a de facto standard by industries. This paper also proposed a 2D Mesh topology for NoC. The NMAP [1] algorithm starts mapping with the most demanding core to the freest neighbors’ router in the mesh. After mapping is complete, it optimizes the placement by trying to switch cores.

In the end, an optimal map is produced. A modification to address multipath routing is also provided in the same paper. This research work is mostly based on the paper [2]. Fig.2 shows a 2D mesh internal which shows routers as the crossbar and connected to routers.

- a. **NoC Platform Basics:** NoCs are multi-hop, packet-switched networks where packets traverse multiple routers from a source core to a destination core. A fundamental aspect of NoC design is topology, which defines the layout and connectivity of on-chip components. Most NoCs employ regular network topologies that can be implemented on a 2D chip surface, commonly referred to as grid-based topologies. Other options include tree-based and irregular or custom topologies, each leveraging specific traffic pattern characteristics, such as traffic locality. However, mesh-based topologies are the most widely used due to their simplicity in routing

algorithms, scalability, and reusability. Fig.2 shows a few details of 2Dmesh interconnection. The Network Interface (NI) part of the core takes care of communication intricacies.

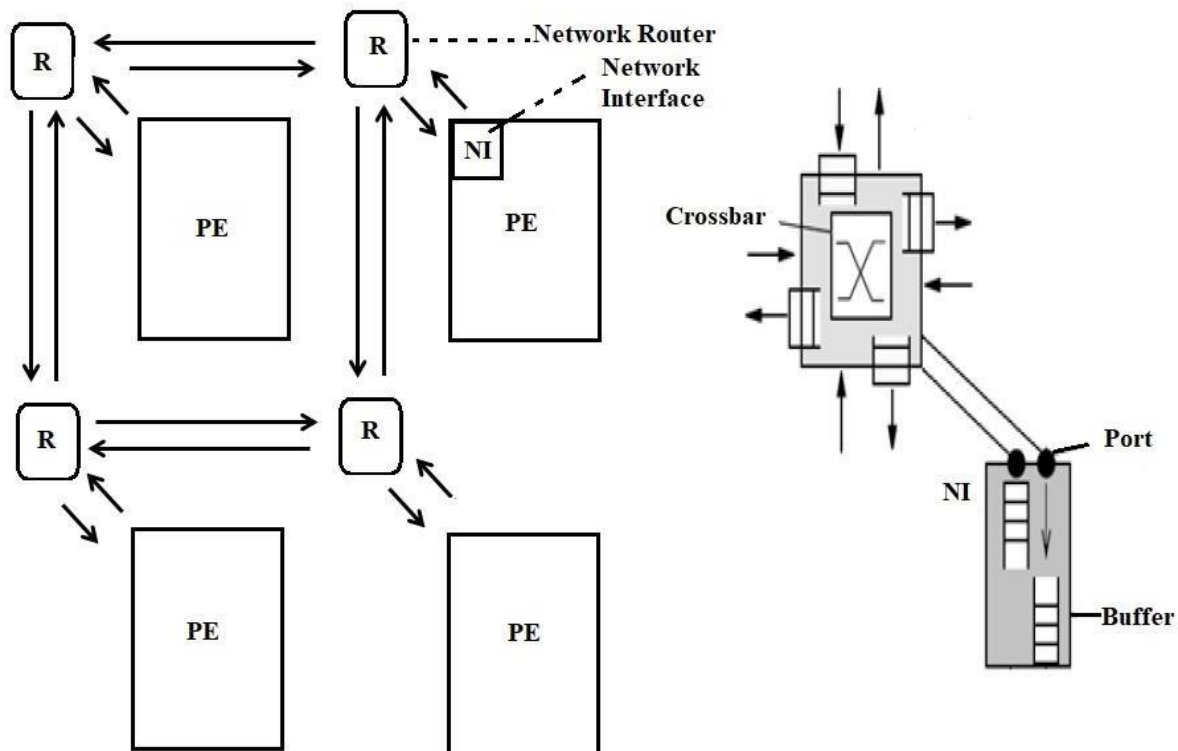

Fig 2. “2D Mesh router and NI details”[3]

b. **NoC Design Process:** Network on chip (NoC) follows a systematic process from concept to manufacturing. The main objective of NoC design is the reuse of IP core. The design process consists of the following.

- A formal description of the task to be performed.
- A general feature of NoC such as Architecture and topology is decided.
- Specialization of general features suitable for a specific or a class of applications.
- Selection of IP cores that will go into the Chip.
- Design of switches(routing algorithm).
- Establishing the protocol.
- Mapping and Scheduling.

Mapping Algorithm: Mapping is the process of placing IP cores of a Task graph to a topology graph. Both the task graph and topology graph are fully connected graphs. The mapping process maps cores from task graph to nodes in topology graph, such that, there is one relationship and the mapping obeys the constraint. The mapping of cores to a topology of NoC is NP-hard[4]. NP-hard problems can't be solved in polynomial time. Hence there is no polynomial-time algorithm to solve the Mapping problem. Authors Carvalho et al. [5] did an extensive study on mapping methods. Authors conclude dynamic mapping is a partial view and static mapping assumes a full description of the task. There are two possibilities when a core mapping can be done.

- i. **Dynamic mapping:** Multimedia, networks or any streaming applications have different processing demand at different times. Until execution, it cannot be decided what the demand will be. This in turn implies the tasks should be scheduled dynamically. If the cores are mapped at run time that is while the task is executed then it is called Dynamic mapping. In the case of dynamic mapping, performance is evaluated and processors are assigned as per the demand by the mapping algorithm. Though this scheme is good it has serious computational overhead, the system has to keep track of all the cores, the total performance of the system and mapping needs. The authors in [5] suggest using greedy algorithms for dynamic mapping, to reduce the computation overhead. Authors in [5] suggest if a task is uniform and there is a processor to track and monitor the slave tasks of the current task then dynamic mapping can be used more efficiently. Dynamic mapping should be preferred until the execution time of application resource demand and sub-tasks are not known. In their work authors conclude “dynamic mapping is acceptable due to its advantages though it has overhead”.
- ii. **Static mapping:** This process assigns cores before the task is executed, that is at design time. It is done after the task and communication infrastructures are decided. Static mapping tries to place cores onto target topology in such a way that the communication cost is always minimum. The static mapping algorithm is run once at design time which removes the computation overhead at execution time [6]. Static mapping is advisable for NoC synthesis if there is no dynamic demand for resources. Static mapping cannot address dynamic load as the tasks are mapped before the execution at design time. Static mapping is only considered for this research work. Static mapping (Fig.2) can be categorized into 2 categories [2],
 1. **Exact mapping:** Exact mapping considers Mathematical programming. The most primitive and naïve approach would be testing all the $n!$ Possibilities (where n is the number of cores) and check which is the best solution. A Still better way is using ILP or MILP for this purpose.
 2. **Search based mapping:** Search-based algorithm employs the searching technique to search for an optimal solution in the search space while satisfying the constraints imposed. Search based algorithms are classified into 2 categories.
 - a. **Deterministic search:** Deterministic search algorithm guarantees to produce the same result for the same set of input. It can be implemented as a state machine. The disadvantage of the deterministic algorithm is they often fail under certain circumstances. That is if the algorithm is in a particular state then it should go to a predetermined state. But if it cannot find the determined state then it fails. As an example, the deterministic Turing machine fails if it cannot determine the next state. Deterministic search comprises branch and bound algorithms. In this approach employees searching solutions in the tree branch. The most economical branch in the tree is searched iteratively until the whole tree is complete. This type of solution is suitable for small problems, as the problem size increases, the execution time increases exponentially. Jingcao Hu and Radu Marculescu [7] discussed such a method and claims it to be better. It is claimed to achieve 60.4% more energy efficient mapping for video and audio applications.
 - b. **Heuristic Search:** Heuristic algorithm quickly finds a solution to a problem. The solution is a good enough approximation of the actual solution. Even though the result produced by

heuristic algorithms is not exact but it is still accepted due to its quickness. Secondly, for some real-life problems, an exact solution is hard to find. In these cases, heuristic algorithms are used to quickly find a good enough solution. Heuristic search utilizes heuristics to guess the solution. Heuristic search is classified into 2 categories.

- i. **Constructive Heuristic:** In constructive heuristics, partial solutions are generated sequentially, and at the end of the mapping process final solution is obtained. Simulated annealing is a constructive method. The constructive heuristic may be with or without iterative improvement. Constructive heuristic search techniques are normally much faster than transformative heuristics. Constructive Heuristic employees a greedy method. The most communicating cores are placed as close as possible. After making clusters of partial solutions, it is checked which clusters generate a better solution. In the case of iterative improvement-based methods, an additional algorithm is used to obtain a better solution. S.Murali et al. [1] proposed NMAP based on a constructive heuristic with iterative improvement. Harmanani and Farah proposed [8] a simulated annealing-based application mapping technique for 2Dmesh. Authors claim their technique minimizes blocking while increasing bandwidth throughput. Z.Lu et al. In [9] proposed cluster-based simulated annealing for mapping onto 2Dmesh. As per the authors, clustering exploits locality, connectivity and distance of the cores. Hence cluster-aware simulated annealing can dynamically be applied within clusters. This in turn results in a good mapping of cores. Authors Orsila et al. in [10] expressed their method using simulated annealing saves 50%time with only 0.3% performance loss. The authors pointed out cyclic graphs are harder than acyclic graphs.
- ii. **Transformative Heuristic:** Transformative heuristics transform some random solution into a better solution. The most common examples are evolutionary techniques, such as Genetic Algorithm (GA) [11], Particle Swarm Optimization (PSO) [12], Ant Colony Optimization (ACO) [13], Bee Colony [14], etc.

A. Genetic Algorithm

Ozcan Ozturk and Dilek Demirbas [15] Described an approach for heterogeneous NoC mapping using a Genetic Algorithm and compared it with the ILP result. Authors in their research work considered performance, energy, temperature, area and communication bandwidth as a constraint. In their work authors computed computation cost and communication cost, and compared them with ILP results. As per the authors, this is the first work that explores the possibility of employing evolutionary computational techniques for optimally placing the heterogeneous nodes in an NoC.

Glenn Leary et al. [16] proposed a multi-objective genetic algorithm (GA) to create a floor plan for an NoC based on a given architecture. Their study incorporates power consumption and router resources as constraints. The authors describe how the approach produces a Pareto curve, where each point represents a tradeoff between power usage and the corresponding number of NoC routers. The effectiveness and quality of the generated solutions were assessed through experiments using benchmark applications and comparisons with other existing

methods. The authors conclude the ILP method produces better mapping results than GA for power consumption. But ILP takes a huge time to produce a solution. On the other hand, GA produces up to 3.5% bad results than ILP in less time. The second constraint, the number of router resources required is solved by GA more efficiently than ILP.

Xinyu LI and Omar Hammami [17] considered a multi objective GA to obtain a Pareto solution such that the designers can decide the core placement. In their work authors used their own TLM and RTL. As per the authors, this work provides a bridge from a high-level model to FPGA execution for accurate NoC design. Experiments on multimedia benchmark applications demonstrate the efficiency of this method.

Wooyoung Jang and David Z. Pan [18] proposed Architecture Aware Analytic Mapping (A3MAP). It is claimed A3MAP reduces bandwidth cost remarkably for regular and irregular topologies too. In their research work authors also compared their results with NMAP [1]. The authors conclude that the mapping time is more in comparison to NMAP. The efficiency of A3MAP is better in the case of irregular topology synthesis than the regular network.

Neal K. Bambha and Shuvra S. Bhattacharyya [19] considered the synthesis of NoC interconnects based upon bandwidth. As per the authors if the number of hops is restricted or if the topology graph is not strongly connected, then multiprocessor scheduling can go into deadlock. In their proposed algorithm authors successfully address this issue using GA.

Naveen Choudhary, M. S. Gaur, V. Laxmi and V. Singh [20] described a method to synthesize custom NoC based on GA. In their work authors expressed custom topology are better suited for Application-Specific SoC. The proposed algorithm generates a custom network topology that is most suitable for the particular application. The authors used floor area and link lengths as the constraints.

Ahmed A. Morgan, Haytham Elmiligi, M. Watheq ElKharashi, and Fayez Gebali [21] discussed GA based method for architecture optimization. In their work authors considered floor area and link delay as constraints. Both the constraints are directly related to the size and performance of the NoC under consideration. The authors suggested by changing the weight age of either constraint, designers can suitably generate a mapping for their requirement.

Giuseppe Ascia et al. [22] described a Multi objective GA based solution for optimizing bandwidth and power consumption. Authors express the Pareto mappings obtained that optimize performance and power consumption can be used in a framework to optimally map at the run time too.

Ge Fen and Wu Ning proposed an algorithm based on GA called GAMR [23]. GAMR considers minimum path mapping for 2D mesh topology-based NoC. In their work authors considered row number and column number both in the chromosome. Their algorithm minimizes communication power consumption and traffic along with the links of 2D mesh topology. Authors have shown the energy consumption and maximum link bandwidths are minimum for mappings generated by their algorithm.

Zahra Emrani and Karim Mohammadi in [24] discussed and compared results obtained by

using Extended Compact Genetic Algorithm (ECGA) and Genetic Algorithm (GA) for optimization of NoC. An interesting observation is ECGA performs consistently over GA. In this work, the authors claim their routing algorithm can efficiently assign deadlock-free, minimal routing paths for traffic traces in a short period.

P.Mesidisand L.S.Indrusiak in[3] discussed the use of genetic algorithm-based mapping for hard real-time applications. In their work authors considered “hard real-time applications running over multi core processors based on wormhole Networks on Chip (NoCs)”.

B. Particle Swarm Optimization (PSO)

PSO belongs to a swarm intelligence-based algorithm. In the case of swarm intelligence, individual particles in the swarm communicate among themselves. In this process for every swarm, a local best and a global best is calculated. These pieces of information are transmitted to all particles. Particles use this information and align themselves according to the current best. At the end of every iteration best values are checked and updated accordingly [12]. In contrast to GA swarm-based algorithms are superior as intelligence is built into every particle in the swarm. In the case of GA, the hypercube which ultimately provides the best solution moves in the search space. The governing factor for movement is the chance of getting a better solution in each step of crossover and mutation [11].

PSO based works are done in [25] by Sahu et al. Authors proposed the PSMAP algorithm in this paper and compared the result with standard results. The author shows, the result obtained is better than earlier results. In their work authors used the different number of participating particles in swarms. Their result shows after a certain population size of swarm no perceivable effect is observed.

In [26] authors proposed a discrete PSO(DPSO) based algorithm for MoT. A DPSO is running multiple PSO simultaneously with the deterministic generation of the initial population. In this paper, authors have compared their results and other standard results available including ILP.

Sahu et al. In [27] proposed a method using a modified Kernighan-Lin graph partitioning algorithm to obtain a mapping solution. The modified Kernighan-Lin partitioning algorithm is recursive. Each recursion divides the graph into 2 partitions, Such that, the weight difference of partitions is minimum. The recursion stops when the at most required number of nodes is present in all the partitions. The resulting partitions represent the closeness of cores. These partitions are then mapped to the topology.

Bahirat and Pasricha [28] have shown a Nano Photonic NoC. A nano photonic NoC uses light as the medium of communication. In the case of electrical NoC electrons carry the signal. In their work, the authors used PSO and Simulated Annealing (SA). In their work authors show PSO yields a better result than SA, and hybrid NoC thus obtained shows more power efficiency as compared to normal electrical NoC.

A. Ant Colony Optimization (ACO)

Ant Colony Optimization (ACO) is an emulation of biological ants' behavior. In a particular sense, ants optimally search for their food. While ants search for food, they put pheromone (a

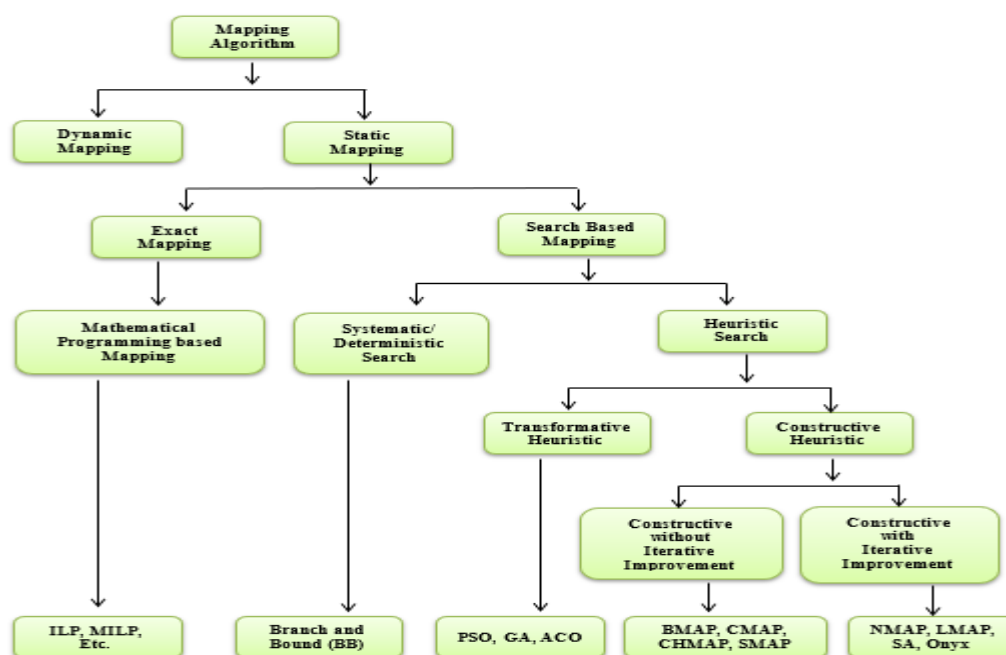

Fig 3. Classification of mapping algorithms [2]

chemical substance) on the trail. The strength of the pheromone signifies how viable is the path to the food [13]. The same concept is adopted in the ACO algorithm. The artificially simulated ants put a weight on the solution they found. When all the ants finished their search the best result is obtained.

ACO based work is done by Wang et al. [4]. In their work authors focused on 2Dmesh and XY routing. The authors also expressed mapping problem is NP-Hard, and such problems are better solved using heuristic methods. The authors show resulting mapping performs very good in comparison to the random mapping method.

B. Bee Colony

In a bee colony, worker bees go for searching of foods(Honey).When an individual bee finds a food source it returns to the hive and starts dancing (wiggling and turning) [14]. This dancing pattern has encoded messages about the source of food in terms of its distance and viability. Then some other worker bees follow the instruction and go for verification. The most viable solution is judged when most of the worker bees perform the same dance.

L.Panetal. in[25]used a chaotic enhanced bee colony method for multi objective application mapping. As per the Authors mapping is NP Complete. Heuristic algorithms can better approximate the solution. The constraints considered by authors are power consumption and wire delay. Authors introduced chaos to prevent premature convergence of the algorithm. For chaos introduction to prevent premature convergence problem authors used one dimensional chaos mechanism. Authors conclude Enhanced Chaos Discrete Artificial Bee Colony performs better than PSO and GA based methods both in run time and mapping result.

6. Conclusion

This article is briefly discussed NoC related works. Specifically, the works related to mapping problem. This chapter begins with basics of NoC and then NoC design process. In NoC design process importance of mapping process is described. Next classification of different mapping algorithm is described. In this chapter majorly discussed methods adopted by different authors to solve mapping problem. More attention is given to transformative heuristic-based work in general and Genetic Algorithm based work in particular.

References

- [1] S. Murali and G. De Micheli, "Bandwidth-Constrained Mapping of Cores Onto NoC Architectures," in Proceedings of the Conference on Design, Automation and Test in Europe -Volume 2, Washington, DC, USA, 2004, pp. 20896–20902.
- [2] P. K. Sahu and S. Chattopadhyay, "A survey on application mapping strategies for Network-on-Chip design," *J. Syst. Archit.*, vol. 59, no. 1, pp. 60–76, Jan. 2013.
- [3] P. Mesidis and L.S. Indrusiak, "Genetic mapping of hard real-time applications onto NoC based MP SoCs #x2014; A first approach," in 2011 6th International Workshop on Reconfigurable Communication-centric Systems-on-Chip (ReCoSoC), 2011, pp. 1–6.
- [4] Amin, Waqar, Fawad Hussain, and Sheraz Anjum. "iHPSA: An improved bio-inspired hybrid optimization algorithm for task mapping in Network on Chip." *Microprocessors and Microsystems* (2022): 104493.
- [5] E. Carvalho, C. Marcon, N. Calazans, and F. Moraes, "Evaluation of static and dynamic
- [6] task mapping algorithms in NoC-based MPSoCs," in International Symposium on System-on-Chip, 2009. SOC 2009, 2009, pp. 087–090.
- [7] Kadri, Nassima, and Mouloud Koudil. "Multi-objective biogeography-based optimization and reinforcement learning hybridization for network-on chip reliability improvement." *Journal of Parallel and Distributed Computing* 161 (2022): 20-36.
- [8] J. Hu and R. Marculescu, "Energy-aware Mapping for Tile-based NoC Architectures Under Performance Constraints," in Proceedings of the 2003 Asia and South Pacific Design Automation Conference, New York, NY, USA, 2003, pp. 233–239.
- [9] H. M. Harmanani and R. Farah, "A method for efficient mapping and reliable routing for NoC architectures with minimum bandwidth and area," in 2008 Joint 6th International IEEE Northeast Workshop on Circuits and Systems and TAISA Conference, 2008. NEWCAS-TAISA 2008, 2008, pp. 29–32.
- [10] Z. Lu, L. Xia, and A. Jantsch, "Cluster-based Simulated Annealing for Mapping Cores Onto 2D Mesh Networks on Chip," in Proceedings of the 2008 11th IEEE Workshop on Design and Diagnostics of Electronic Circuits and Systems, Washington, DC, USA, 2008, pp. 1–6.
- [11] H. Orsila, E. Salminen, and T. D. Hamalainen, "Parameterizing simulated annealing for distributing Kahn Process Networks on multiprocessor SoCs," in International Symposium on System-on-Chip, 2009. SOC 2009, 2009, pp. 019–026.
- [12] O. Ozturk and D. Demirbas, "Heterogeneous network-on-chip design through evolutionary computing," *Int. J. Electron.*, vol. 97, no. 10, pp. 1139–1161, 2010.

- [12] Muoka, Pascal, Daniel Onwuchekwa, and Roman Obermaisser. "Adaptive Scheduling for Time-Triggered Network-on-Chip-Based Multi-Core Architecture Using Genetic Algorithm." *Electronics* 11.1 (2021): 49.
- [13] Seetharaman, Gopalakrishnan, and Debadatta Pati. "Energy consumption and performance comparison of DE optimization and PSO-based IP-core mapping technique for 2D and 3D network-on-chip." *Semiconductor Science and Technology* 36.8 (2021): 085015.
- [14] Fang, Juan, Tingwen Yu, and Zelin Wei. "Improved ant colony algorithm based on task scale in network on chip (NoC) mapping." *Electronics* 9.1 (2019): 6.
- [15] Amin, Waqar, et al. "Performance evaluation of application mapping approaches for network-on-chip designs." *IEEE Access* 8 (2020): 63607-63631.
- [16] G. Leary, K. Srinivasan, K. Mehta, and K. S. Chatha, "Design of Network-on-chip Architectures with a Genetic Algorithm-based Technique," *IEEE Trans Very Large Scale Integr Syst*, vol. 17, no. 5, pp. 674–687, May 2009.
- [17] X. Li and O. Hammami, "Multi-objective Topology Synthesis and FPGA Prototyping Framework of Application Specific Network-on-chip," in *Proceedings of the 21st Edition of the Great Lakes Symposium on Great Lakes Symposium on VLSI*, New York, NY, USA, 2011, pp. 55– 60.
- [18] W. Jang and D. Z. Pan, "A3MAP: Architecture-Aware Analytic Mapping for Networks-on-Chip," in *Design Automation Conference (ASP-DAC)*, 2010 15th Asia and South Pacific, 2010, pp.523–528.
- [19] N. K. Bambha and S. S. Bhattacharyya, "Joint Application Mapping/Interconnect Synthesis Techniques for Embedded Chip-Scale Multiprocessors," *IEEE Trans. Parallel Distrib.Syst.*, vol. 16, no. 2, pp. 99–112, 2005.
- [20] N. Choudhary, M. S. Gaur, V. Laxmi, and V. Singh, "Genetic algorithm based topology generation for applicationspecificNetwork-on-Chip," 2010, pp.3156–3159.
- [21] A. A. Morgan, H. Elmiligi, M. W. El-Kharashi, and F. Gebali, "Multi-objective optimization for Networks-on-Chip architectures using Genetic Algorithms," in *Proceedings of 2010 IEEE International Symposium on Circuits and Systems (ISCAS)*, 2010, pp. 3725–3728.
- [22] G. Ascia, V. Catania, and M. Palesi, "Multi-objective mapping for mesh-based NoC architectures," 2004, p. 182.
- [23] G. Fenand W.Ning, "A minimum-path mapping algorithm for 2D mesh Network on Chip architecture," in *IEEE Asia Pacific Conference on Circuits and Systems*, 2008. APCCAS 2008, 2008, pp. 1542–1545.
- [24] Z. Emrani and K. Mohammadi, "A technique for NoC routing based on Extended Compact Genetic Optimization Algorithm," in *2011 19th Iranian Conference on Electrical Engineering (ICEE)*, 2011, pp. 1–1.
- [25] P. K. Sahu, P. Venkatesh, S. Gollapalli, and S. Chattopadhyay, "Application Mapping onto Mesh Structured Network-on-Chip Using Particle Swarm Optimization," 2011, pp. 335–336.

- [27] P.K.Sahu,A.Sharma,andS.Chattopadhyay,“Application Mapping Onto Mesh-of- Tree Based Network-on-Chip Using Discrete Particle Swarm Optimization,” in 2012 International Symposium on Electronic System Design (ISED), 2012, pp. 172–176.
- [28] P. K. Sahu, N. Shah, K. Manna, and S. Chattopadhyay, “An Application Mapping Technique for Butterfly-Fat-Tree Network-on-Chip,” 2011, pp. 383–386.
- [29] S. Bahirat and S. Pasricha, “A Particle Swarm Optimization approach for synthesizing application-specific hybrid photonic networks-on-chip,” in 2012 13th International Symposium on Quality Electronic Design (ISQED), 2012, pp. 78–83.
- [30] L. Pan, Z. Li, andX.Ling,“NoC Multi-Objects Mapping Based On Enhanced Chaos Discrete Artificial Bee Colony Algorithm,”*Int. J. Future Comput. Commun.*,pp. 116– 120, 2012.

Examining Corporate Social Accountability of Organizations- A Case of Tata Krosaki Refractory Limited (TRL), Odisha, India

Ashwini Kumar Patra¹ & Dr. Tattwamasi Paltasingh²

Corresponding author: bibhupaikaray1979@gmail.com

Revised on 23th Aug 2025 and Accepted on 22 Oct 2025

Abstract:

Over the past decade, Corporate Social Responsibility has risen in global prominence and appeared as a substantial feature of business philosophy, depicting the impact of business on society in the perspective of sustainable development. The CSR as a process includes execution of wide range of activities, which facilitate in improving the social, environmental and economic impacts of business. It performs a decisive function in the sustainable business approach, which accentuates on how to maximize the effectiveness of resources with least consumption, examination of resources devoid of exploitation and uphold surplus symmetry of resources for future cohort. This paper has elucidated the gravity of CSR programme in one organization's functional and operational process, i.e., TATA Refractory Limited (TRL)-Krosaki and the impact of such programme on lives of the community member. The CSR expenditure information on various thematic areas was collected from published annual reports of the organization and analysed. It is observed that the Governing Body has increasingly realized the importance of CSR programme in its peripheral areas, and allocated the increasing amount of fund to execute strategic CSR programme. Significant changes are observed in the lives and livelihood of the beneficiaries and its adjoining areas of the industry.

Key Words: CSR , Sustainable changes, Strategic intervention, Corporate Social Accountability

1. Introduction

Corporate Social Responsibility (CSR) is a medium for the corporate houses through which they endorse commitment to make the business function in an ethical manner and support to economic development. Whilst, the social responsiveness behaviorism at bringing improvement in the quality of life of the workforce and their families as well as of the local community and society at large. In general, social responsiveness is concerned about dealing with organization's operational and planned actions towards addressing the thematic issues like health, safety, environmental protection, human rights, human resource management practices, corporate governance, community development, consumer protection, labor protection, supplier relations, business ethics, and stakeholder rights.

Further it deals with the relations between companies and the society and especially it examines the impact of such philanthropic activities on individuals. A socially responsible company can be considered as an institution for economic prosperity, social equity and for environment protection. In order to comprehend the contribution of businesses to the country's prosperity, all the companies have to be involved in the CSR activity as per the amendment in the Company Act 2013. In view of that, the business house whose annual revenue of Rs. 1,000 crore and

more or a net worth of Rs.500 crore and more or net profit of Rs.5 crore and more will have to spend at least two percent of their three-year average net profit each year on CSR activities. Moreover, the business houses necessitate spending CSR money in project approach with pre-defined indicators, financial plan, period etc. It has also been made indispensable for businesses to make known their CSR Guidelines, projects carried out under CSR programmers, amount spent in their report and there is the provision for a separate format for accomplishment according to CSR rules. Based upon it, the majority of the Indian companies started discarding the conventional method of engagement with CSR, rather adopting strategic method which shall be responsible for making a significant impact in the lives of target beneficiary and helps in integrating the total business process into a sustainable business strategy.

2. Research Evidences on Corporate Social Responsibility and its Significance

Evolution and Conceptual Understanding of CSR

Social responsibility initiatives of the corporate organization have provided a distinctive opportunity to stand up to the challenge of availing equal access to benefits and facilities. Inclusion of ethical measurements in the business process like accountability and transparency facilitates in transforming the business organization into socially sensitive and responsible and be able to bring a remarkable change in the society. With this background, Choudhury (2009) illustrates CSR as an essential part of the modern business. CSR resonates the goals, vision, mission, culture and the plans of the corporations. It describes what and how they appear further than the profits. It was observed even if the number of CSR projects increased in India, until now there is a lack of clear metrics or framework for formulating and assessing their definite impact in augmenting the societal state of affairs.

Katara (2014) in his study depicts that attitude of people, business houses and societies are the reason behind the changing trends of CSR. And with the changing attitude, CSR is not anymore only about philanthropy but way more than that and banks are following triple bottom line principles in their CSR policy. Satpathy and Paltasingh (2019) mentioned in their study that idea of CSR was well rooted in Indian ethos and its cultural values. In the name of CSR, many philanthropic activities were undertaken by the rich business houses. Gandhiji's had promulgated the Trusteeship model and endorsing this model for the business houses to win the trust and confidence of the people, The feature of this philanthropic model of serving the people changes with globalization and becomes a multi-stakeholder perspective process. In India, new companies act has been formulated and makes mandatory to include CSR as a functional activity in the Corporate System and Procedure.

CSR and Legal Framework

[Vermaand Vijaya \(2014\)](#) found that the Companies Act 2013 has made a provision for corporate to spend standard 2% of the net profits towards Corporate Social Responsibilities

(CSR). They studied the spending directive of corporate towards CSR programme. The study included those companies listed in BSE Sensex from 2001 to 2012 and out of these thirty companies were figured in sample list. The information collected on account of particulars of CSR expenditure of companies, amount of CSR expenditure as proportion of sales and profits for each year and on an overall basis. The analysis illustrated that in comparison to proportion of revenue and profits during the phase of voluntary spending; the company's CSR expenditure has been very low. Moreover, the results also revealed that in most of the companies' priority list, the expenditure on environment and pollution control has not received a place. Nonetheless, while evaluating the effectiveness of CSR programme, the fundallocation cannot be taken as sole indicator; still, it serves as an imperative pointer of the engagement of companies with society. Hence, it can be concluded that inclusion of this condition is an apt step by the regulators to make corporate socially more responsible.

Maira (2013) raised doubts about the legitimacy of spending of 2% of companies profit on CSR and expressed the apprehension that the politicians may persuade the corporate to divert these funds towards their corpuses and desired causes. Researcher had observed that the innovation of new institutions in the field of economy, polity, environment, and knowledge had increased the level of awareness of the society, and this had forced the policy makers to bring such innovative changes in the domain of governance. It was concluded that the mandatory CSR spending was bothmeagre and one whose time has passed.

3. CSR in Practice: Public vs. Private Sector

Bordoloi and Mukharjee (2017) have compared the CSR programmes of preferred public and private sector corporate commercial banks. While ranking, average six years of profits from 2007 to 2013 of these banks were taken into calculation and ranked accordingly. The majority of the commercial banks had spent a little amount of their preceding year net profit subsequent to tax spent on existing year CSR activities. Conversely, the majority of the commercial banks apart from SBI from the public sector, ICICI and Axis bank from private sector had revealed their proportion of preceding year net profit following tax spent in existing year CSR activities in the fiscal year 2012-13 only. Whilethe majority of the commercial banks apart from ICICI bank have not invested the approved proportion of standard three preceding year net profit after tax spent on the existing year CSR activities in the fiscal year 2014-15. Martolia (2016)had examined the implication of CSR in India for the sustainable growth of the country. The researcher made a comparison of the pattern of CSR expenditure between companies in the public and private sectors. The study revealed information among the Indian Companies that the CSR expenditure as a proportion of profit after tax is not equal to 2%.Moreover, there is no considerable disparity in the CSR expenditure and transparency score of Public & Private Sector Companies. The proper system of accountability & transparency can bring about a noteworthy change in the society by making the organization collectively receptive and accountable.

Ramesh and Mendes (2016) have elucidated that it becomes obligatory for business houses to accomplish CSR activities. Accordingly, they compared the preparedness and spending pattern

of Corporate Social Responsibility (CSR) between the private and public corporate houses in India. It was observed that out of one hundred corporates are taken as the sample; the private corporate houses are spending more than public corporate houses. The high execution rate and better performance among the private sector companies place them in a comfortable position than the public-sector companies. The public companies require introspecting and necessitate taking suitable action on their CSR spending and execution. In order to make CSR effectual in the public sector corporate houses, government needs to extend its support and require involvement.

Sahu and Panigrahy (2016) have discussed the function of social responsiveness behaviour of corporate houses in dealing with sustainable development issues. The researcher compared the CSR programme of private and public sector corporate houses on a multi-dimensional basis. They chose Iron & steel and Automobile manufacturing industry in India to establish this comparison. Considering the need of time and stakes of the organization in long run, the significance of CSR has been transformed from the conventional self-interested deliberation to socio-economic approaches. It was established that business should not be run only on profit motive. Further, this must be apparent through their association with various community development activities. Business firms in the competitive business environment follow the basics of business ethics to retain customers and enhance its market share by investing in CSR initiatives. Business firms are also responsible for providing hygienic surroundings for the society as well as for a consistent and long-standing sustainable development of business; the firm should use CSR as a strategy, which aims at mutual development of company and the community all together.

Singh and Das (2018) highlighted the various guiding principles for banks in India with special reference to CSR and at the same time the areas focused by banks for implementation of CSR activities. The study was confined to comparison of CSR activities of one public sector bank, SBI and one private sector bank, ICICI. It was of great importance and to be under consideration while designing the CSR initiatives, as these initiatives need careful planning and at the same time implementation mechanism, the reason being that, a single CSR initiative, the way it was implemented for one organization may not necessarily be as beneficial and effective as for the other organizations too. The same was in the case of CSR initiative of State Bank of India and ICICI. The primary concern for both these institutions were same, the area they focus to implement their CSR activities were same, but the approach was different for both the banks.

CSR and Financial Performance

The results of a CSR ranking study by Majumdar, Rana and Sanan (2015) found that there were substantial distinctions between the expenditure of the manufacturing and services companies in 2014. For absolute spends, manufacturing spent more and was reasonably more broadly dispersed. Service sector spent comparatively much lower amounts. The researchers in addition examined spends as a percentage of profit where the same propensity was simulated - with manufacturing being more widely dispersed than either services or consumer goods. **Verma**

and Vijaya (2014) analyzed CSR expenditure as a proportion of profits and revenue during voluntary and mandatory phases.

4. CSR and Sustainable Development

Hussain and Hussain (2015) observed that in recent period, the alarming issue which has made everybody worried that the fast exhausting of the earth's natural resources and interrelated environmental issues. In that context, prominence is given upon sustainable development, which becomes a matter of issue for academia, corporations, government and society in general. Many research works on corporate social responsibility (CSR) concluded the findings that governance process of corporate organization tresses upon sustainable development and address it through CSR programme. It is realized by the corporate that the natural capital is limited and upon which the society's economic, social and cultural well-being are based. Hence, it should be judiciously used for survival. Interestingly, many authors believe that the society (customers) rates the corporations based upon their extent of involvement with socially responsible activities. Accordingly, it becomes easier for the business for long-term survival as customer is the primary stakeholder of the business. **Sahu and Panigrahy (2016) emphasized that shift from profit-focused to socio-economic approaches in CSR for sustainable business and societal development.** Sharma and Kiran (2012) observed that in India, many firms have taken the initiatives of CSR practices which have met with varying needs of the society. Although India has entered a transformational change by involving into new CSR initiatives, but still a lot has to be done in this area.

5. CSR and Poverty Reduction

Boyle & Boguslaw (2007) examined the current roles of the corporations, who have a role in playing in poverty reduction in reference to both developed and developing nations. The article presents a preliminary investigation of a change of the role of the corporate sector on the subject of government, nonprofit stakeholders, and the poor. In addition, the article has assessed the various dynamism of poverty and contributions of corporations in reducing poverty in direct and indirect manner. A classification of impending measures on the part of the companies and an analysis of diverse fields pertaining to impact on business, society, and corporate citizenship are appraised in the study. The article was completed with a call for a more explicit acknowledgement of poverty in the corporate citizenship domain. All together the corporate sector has to take the leadership role in making the poverty as the issue of concern in the path of development, structure it in a way that will speed up its reduction, and to take an energetic responsibility in poverty lessening efforts.

Jorge A. Arevalo and Deepa Aravind (2011) concluded in their study that the stakeholder approach is the most favoured CSR approach in most Indian firms. The imperative causes which propel the Indian firms to pursue CSR are considerate or the ethical cause followed by the planned or profit cause. Further, the results point out that the added noteworthy

impediments to CSR execution are connected to need of resources, subsequently involvedness and difficulty of bringing correlation between quantitative and qualitative objectives of CSR.

CSR and Corporate Image

Shweta (2011) corporate firms are now progressively more concerned in improving their representation in society as opposed to focusing on profits only. Better image or benevolence in the market endows with long term sustainability. Hence, this has become the foremost objective of corporate sector.

6. Reporting, Accountability, and Transparency

Enock & Kuvempu (2014) measured the CSR programmes of Tata Company and ITC Company on different thematic areas i.e. environmental friendliness, social accountability, employee's safety, human rights promotion and healthcare etc. The study while focusing upon the reporting techniques observed that the two above mentioned private companies of the country are directly occupied in social responsibility activities from innovation in agriculture and education to save the environment. It is concluded that both the companies have programme intervention in similar areas like environment, education, community involvement and health care activities and it is inevitable and part of inclusive and wider sustainable development goal of the company

Katara (2014) in his study depicts that attitude of people, business houses and society are the reason behind the changing trends of CSR. And with the changing attitude, CSR is not anymore only about Philanthropy but way more than that and banks are following the triple bottom line principles in their CSR policy.

Katara (2014) in his study depicts that attitude of people, business houses and society are the reason behind the changing trends of CSR. And with the changing attitude, CSR is not anymore only about Philanthropy but way more than that and banks are following the triple bottom line principles in their CSR policy.

7. Study Significance

In a rapid changing business environment, the business organization has to focus upon ethical business practices and transform its trustworthy and loyal factor among the stakeholders. Further, it is imperative for the organization to be accountable and exhibit high concern for overall development of society. This practice upholds the company's standing in competitive business scenario and earns accolades from the regulators.

Meanwhile, for the sake of deep researches on CSR practices in different organizations and intentions of governing body towards allocation and fund utilization, a detailed analysis of CSR practices need to be conferred that commence from planning, formulation, monitoring and execution of the programme in the organization. The CSR priority of one organization is totally different from the other organization, but the focus is to bring overall development of the community and contribute towards the growth of the country. It has to serve varying needs of

the society and to increase the trust of the stakeholders towards the organization. Therefore, this research paper focuses upon studying types and thematic aspects of CSR practices and fund utilization pattern by the case organization, i.e. TATA-Krosaki Refractory Limited. Hence, this study is conducted with the following objectives:

- Finding out nature and extent of different CSR activities initiated by TRL in its peripheral areas.
- Assessing the impact of CSR activities on lives and livelihood of the beneficiaries.
- Ascertaining the significance of CSR activities in the governance process of case organization.

8. Methodology

The study is based on case approach and a qualitative one. The study has explained the CSR programmers of case organization located in Jharsuguda district. The case organization TRL-Krosaki is a reputed Private sector company established in 1958. The main purpose of the study is to establish acquaintance about type of activities executed in different thematic sectors of CSR programmer and its implication upon the lives of the beneficiaries. In this regard, secondary information was collected from the published CSR reports and annual reports of the companies from the year 2014 to 2020. The study has analyzed the fund allocation pattern, fund utilization in different CSR activities, governance process etc. In order to supplement the collected information, some success case story is also cited in the study. Supplement to it, the second part of the study was intended to measure the impact of the programmer on live and livelihoods of the beneficiaries. For this purpose, the beneficiaries were selected on a simple random basis from the peripheral areas of the case organization. The interview schedule was administered and information was collected on effectiveness of the CSR programmer of the case organization. In order to supplement the collected information, some success case story is also cited in the study.

9. Results and Analysis

Major CSR activities of Tata-Krosaki Refractory Limited (TRL-Krosaki),

TRL Kroaski, having more than 60 years of existence in Odishais undertaking CSR activities in the regions since 1970. The Company has initiated its CSR programme in 70 villages of Lakhanpur Block of Jharsuguda District. The district is located in Western part of Odisha, India. The community members of these 70 villages are the key beneficiaries of company's CSR programme. Consistent with the Group principle, the company has launched many focused CSR initiatives in the areas of Health and sanitation, education, self-employment & entrepreneurship development, women empowerment, Literacy and awareness, infrastructure development and support etc. for holistic development in the lives of village community. It has received TERI CSR award from the President of India in 2009 for its praiseworthy work in correction of cleft lips & cleft palates. The company has a dedicated CSR team comprising of three officers and five field workers. A separate CSR office with three vehicles is located

outside the factory premises for easy access of the villagers. The important CSR activities of the company are as follows.

Promotion of employability

Considering the growth opportunities in the area created by rapid industrialization and the fact that there is an acute shortage of required skill set, Employability emerges out as the most important focus area for intervention. Driven by this social need, TRL Krosaki, as part of its Golden Jubilee celebrations invested of an amount of approx. Rs. 1.8 Crores in April, 2009 and laid the foundation of a state-of-art Rural Self Employment Training Institute (RSETI) at Belpahar. At present, the institution has received the accreditation of only A+ category RSETI in Odisha and the third best RSETI in India as recognized by Rural Development Department, Government of India.

The establishment of this institute is an exclusive step towards promoting employability and entrepreneurship amongst the unemployed youths particularly from SC & ST community. The institute has designed various short durations skill enhancement training programme for unemployed youth. These skill enhancements in diverse trades like welding, carpentry, rod bending, electric wiring, plumbing and pump set repairing, repairing of TVs and electronic appliances etc., facilitates them either to become self-employed or find wage employment or any entrepreneurship venture. Appreciating the objectives and activities of the institute, State Bank of India is in association with TRL Krosaki supervising the institute from March, 2010. National Bank for Agriculture and Rural Development (NABARD) & District administration are also involved in this initiative. The institute offers free residential training has earned reputation among all stakeholders and trained more than 6500 unemployed youth during last ten years out of which more than 86% are gainfully engaged.

As a part of its post-training follow up action, the institute maintains the data base and monitors the improvement of the passed-out trainees for two years. In order to promote entrepreneurship endeavour, the institute proposes initial planning support by arranging counselling sessions by the Banks, District Industries Centre etc. This assists in explaining to them about various Govt. schemes and sources of financial support. Besides, association of State of India with the institute helps in solving fund related issues in case of a self-employment or entrepreneurship venture. The institute also arranges meeting with contractors, industries with the passed-out trainees to facilitate wage employment for some of the trainees.

Education

Education programmes under CSR comprises of organizing awareness classes on Quality of Life in association with Central Board for Workers' Education (CBWE) (623 villagers have been covered in 2018-19). Awareness programmes on financial literacy, government schemes, safety, health, hygiene, environment protection, etc. are conducted. Further the company provides support services to the schools through construction of infrastructure facilities like school buildings, hostel buildings, Library Halls, supply of desks and benches, beds for hostels, Electrical Transformer and Solar light, construction of toilets etc. Besides that the organization is also engaged in providing Merit cum Scholarships to the poor students and it bears the school

fees of all the students from BPL families. In this process, the company bears the fees of the meritorious students in residential schools and also in technical education

Health

Operation Khushi for correction of cleft palates and cleft lips has brought back smiles on the faces of 1294 by March 2019. The company bears all the expenses for bringing the beneficiaries and their attendants to TRL Krosaki Hospital, Belpahar, their food expenses, medicine, living expenses, etc. TRL Krosaki Hospital is accredited with Smile Training Foundation of the United States for its contribution in this field. Former Tata Group Chairman, Ratan Tata has donated a new Tata Nano car to the hospital for their good work.

The company conducts health camps, family planning operation camps, eye camps, etc. for extending medical examination and distribution of medicine free of cost. In 2018-19 the company conducted 10 camps and covered 2723 persons in Lakhanpur block and provided free health care in these camps. The company had also conducted eye camp and 55 patients were benefitted with cataract operation for free of cost during. In addition to this the company extends free medical consultation to needy patients every Wednesday in its hospital. The company joins hands with Government of Odisha in organizing Polio immunization camps, family planning camps and creating awareness on various diseases.

Drinking Water and Sanitation

“Jagruti” project is initiated as a Public Private Participation (PPP) mode in joint collaboration with Rural Water Supply and Sanitation (RWSS-A Govt. Department), Gram Vikas (National Based NGO), Local MLA, TRL Krosaki and beneficiaries. Under the banner of this project the beneficiaries are provided with toilet, bathroom and supply drinking water facilities to each and every household. A committee is established at the village level to monitor and spread awareness among the beneficiaries regarding the benefit of supply drinking water facility and to stop open defecation. Till date 2337 numbers of toilets are constructed in 35 villages of Lakhanpur block. Nevertheless, the company has dug thousands of dug well and bore wells in different villages of Lakhanpur block since 1970s and established two water purification plants in village Bisiutka and Katujhor for giving access to safe drinking water to the villagers. Besides that the company ensures safe drinking water facilities to the Belpahar Municipality through permanent pipeline supply from the plant and supplies water tanker if any water crises arise during the summer season.

Sustainable livelihood

In order to enhance the income and ensure sustained livelihood of the farm families, the company lay emphasis on strengthening the farming process as its mainstay in this region. Hence, the efforts are directed towards providing support services to agriculture through Lift Irrigation points, canals, water pumps and fittings, Pump Houses, Deep Bore Wells and Natural Stream channels for cultivation in villages like Kureimal, Bhutia, Nachenmura, Samarbagha, Kutrapali, etc. This process has benefitted nearly 500 families; most of them are marginal farmers and under-privileged community. The farm families are oriented and

encouraged on adoption of new methods of farming and financial supports are provided to rural youth to promote pisciculture along with the agriculture.

Environment

In order to conserve the natural resources, the CSR department organizes VanaMahotsavs in each and every year in schools, peripheral and adjoining areas of the company. The company has developed a nursery in Belpahar to supply saplings to the villagers. Under this programme, six lakhs of plants have been planted in and around the township. The company targets to distribute nearly 30,000 saplings in each every year to develop a green belt in its peripheral and adjoining areas of Jharsuguda district.

Ethnicity

The company intends to promote the local culture, art and craft and extends material support to various social events/Social Functions to promote local culture. Facilitates local craftsmen to participate in Annual Functions and Exhibitions to create awareness and promote art and craft in the villages. The company also organizes Village Fair in its township for providing a platform for selling handicraft and decorative items made by the local villagers.

Infrastructure development

Infrastructure supports to the community is a major CSR activity of TRL Krosaki. On the request of the Municipality Council of Belpahar, Citizen's forums, village Development Committee (VDC) and the School Managing Committee (SMC), the company takes up different projects like construction of Public Toilet and Bathroom, Community Hall, Library room, bathing ghats, village mandaps, community kitchen and dining places, etc every year. The company has constructed community halls in its peripheral villages. In the recent past, the company has partnered with Belpahar Municipality for taking up Town Beautification projects in Belpahar.

Sports

Besides the strategic activity, the organization is also involved in promotional activity like sports in its peripheral areas. For promotion of sports the company not only provides financial help and sports item to schools, youth clubs, village sports associations, etc. for organizing football, volley ball and cricket tournaments in villages, but also develops sports infrastructure and installing open gym equipment in the villages. In order to promote a positive health among the citizens of Belpahar, the company organizes annual events like Belpahar Mini Marathon, International Yoga Day, etc.

Each successive year the organization has sanctioned CSR budget to spend on different CSR activities. Depending on the requirement of the thematic areas and priority need of the community, the CSR committee has allocated its fund to spend on above mentioned thematic areas. In this context, four years of budget and expenditure pattern has taken into consideration and its analyses have been presented in subsequent sections.

Table-1: CSR Budget and Expenditure pattern of TRL

TRL KROSAKI REFRACTORIES LIMITED, BELPAHAR							
BUDGET & EXPENDITURE FROM 2014-15 TO 2017-18							
Sl #	Financial year	Average net profit (for last 3 financial year) (Fig. in lakhs)	Prescribed CSR expenditure (2% of average net profit)	Total amount spent (Fig. in lakhs)	Total amount spent in unspent	Extra amount spent (In lakhs)	Extra amount spent in (%) (C4/C2*100) - 2%
	1	2	3	4	5	6	7
1	2014-2015	1613	32.26	109	0	76.74	4.75%
2	2015-2016	641	13	69	0	56	8.76%
3	2016-2017	1149.53	22.99	81.40	0	58.41	5.04%
4	2017-2018	2727	54.44	81.68	0	27.44	1%
5	2018-2019	4,980.82	99.62	104.70	0	5.08	0.1%
6	2019-2020	8551.14	171.02	175.13	0	4.11	0.04%
*7	2020-2021	Due to occurrence of COVID, the CSR fund was diverted to Prime Minister CARE Fund					
TOTAL		19, 662.49	393.33	620.91	0	227.78	19.69%

Source. Annual Reports of TRL

India is a torch bearer of the movement towards CSR and has the unique distinction of being the only country to mandate through statutory provisions that a company which satisfies the benchmarks laid down in the statute should embrace CSR. Accordingly, TRL to acquire reputation of socially responsible organization gets engaged in philanthropic activities in its peripheral areas since long. The example of involvement in CSR programme is represented through consecutive four years average net profit of the company, prescribed CSR expenditure and additional amount spent than the allocated budget for the CSR programme.

It is observed that in each and every year the company had spent an extra amount than the prescribed budget for carrying out CSR programmes. Supplement to it, the governing body of the company monitored and ensured total utilization of fund in carrying out CSR programmes in its peripheral areas. In 2014-2015, the company had spent 4.75%, in 2015-2016 the amount spent on CSR programme was 8.76%, in 2016-2017, the amount spent was 5.04%, whereas in 2017-18, the extra amount spent was 1 % than the amount allocated for carrying out CSR programme. While taking into account the organization's 6 consecutive years of financial statement, it is observed that the Company has spent extra amount than the prescribed expenditure for CSR programme. Further, the average net profit of the organization has been

substantially increased in the year 2018-19 and 2019-20. Accordingly, the prescribed fund for carrying out CSR activity is increased. In the financial year, the CSR fund has been diverted to PM CARE Fund due to outbreak of COVID.

Table-2: TRL KROSAKI Refractory Limited

TRL KROSAKI Refractory Limited													
CSR Expenditure in different sectors													
Sl. #	Thematic Programme Areas	2014-2015		2015-2016		2016-2017		2017-18		2018-19		2019-20	
1	Education	29.01	26.7%	21.87	31.7%	27.43	33.7%	33.8	41.38%	21.24	18.34%	37.44	21.37%
2	Health	7.18	6.59%	3.40	4.92%	6.16	7.56%	5.92	7.24%	5.06	4.36%	5.4	3.08%
3	Drinking water and sanitation	20.35	18.7%	7.92	11.47%	13.31	16.35%	10.59	12.96%	7.51	6.48%	9.13	5.21%
4	Agriculture	4.64	4.26%	0.63	0.43%	4.2	5.15%	0.29	0.35%	2.73	2.35 %	24.6	14.04%
5	Sustainable livelihood	25.53	23.46%	19.86	28.78%	19.08	23.43%	25.71	31.47%	26.56	22.93%	31.1	17.75%
6	Ethnicity	2.2	2.02%	2.43	3.52%	2.64	3.24%	2.76	3.37%	2.54	2.19%	3.88	2.21%
7	Environment	17.55	16.13%	8.11	11.75%	6.66	8.18%	1.65	2.02%	0.9	0.7%		
8	Rural Infrastructure	1.18	1.08%	4.27	6.18%	0.9	1.10%	0.18	0.22%	44.74	38.63%	46.75	26.70%
9	Sports	1.15	1.05%	0.93	1.34%	1.02	1.25%	0.72	0.88%	4.62	4%	16.87	9.63%
TOTAL		108.79	100%	69	100%	81.4	100%	81.68	100%	115.8	100%	175.13	100%

CSR Expenditure in different Thematic Programme Areas

Source: Annual Reports of TRL

As the National Voluntary Guidelines on Social, Environmental and Economic Responsibility of Business 2011 has laid emphasis upon one of the core elements like activities for social and inclusive development, hence, the organization engaged in implementation of CSR programme stresses upon planning and execution of different strategic activities, which is responsible for bringing tangible changes in the target areas. In order to bring qualitative changes in the lives of the beneficiaries, it is imperative to provide basic education, access to water and sanitation facilities and supplement of sustained income opportunities. From the analysis of last four years CSR expenditure in different sectors, it is observed that in each and every year the company has focused upon enhancing the literacy status, strengthening the infrastructure facilities in the educational institutions, strengthening the livelihood and providing drinking water and sanitation facilities to the target beneficiaries. In 2014-15, the organization has spent maximum amount of funds in education sector, followed by sustainable livelihood, drinking water and sanitation and environment. In 2015-16 out of 69 lakhs rupees spent in CSR programme, the company had spent 21.87 lakhs (31.7%) towards Education followed by Sustainable livelihood, Environment protection and Drinking water and sanitation programmes. In 2016-2017, the

company had spent 33.7 % and 23.43%, in 2017-18, the company had spent 41.38% and 31.47% on thematic areas like Education and Sustainable livelihood respectively.

Table-3: Last 6 years Expenditure pattern in different CSR activities

Thematic Areas	Programme	Amount Spent in last 6 yrs (Figures in lakhs)	Amount spent in last 6 yrs(in %)
Strategic Activities			
Education		170.79	27.01
Health		33.12	5.23
Drinking water and sanitation		68.81	10.9
Agriculture		37.09	5.86
Sustainable livelihood		147.84	23.38
Ethnicity		16.45	2.6
Environment		34.87	5.51
Rural Infrastructure		98.02	15.5
Promotional Activities			
Sports		25.31	4
Total		632.3	100

Source: Annual Reports of TRL

The above-mentioned table represents last 6 years expenditure pattern of the company in various thematic areas of CSR programme. It is observed that in last 6 yrs, the company had spent more on Education. It had spent 170.79 lakhs, which is 27% of its total expenditure. Corresponding to the above thematic areas, the next priority areas for the organization is to strengthen the livelihood of the beneficiary, where it had spent 147.84 lakhs, i.e., 23.38 %. At the same time, the organization has emphasized upon improving the rural infrastructure facilities, maintaining health and hygiene in the areas and insists upon providing pure drinking water and sanitation facilities to the families. The company has given emphasis upon strategic CSR activities than the promotional CSR like sports. It indicates that the organization is more concerned about bringing the changes in lives and livelihood of the target beneficiaries of the peripheral areas.

Analyzing the Impact of CSR Programme

Table-4: Demographic profile of the respondents

Gender	Nos. of Respondents	Age Group	Nos. of Respondents	Qualification	Nos. of Respondents	Occupation	Nos. of Respondents
Male	67(67%)	Below 18	-	Below 10 th	-	Labourer	11 (11%)
		18-35	33 (33%)	10 th	24 (24%)	Agriculture	12 (12%)
		36-53	28 (28%)	10+2	31 (31%)	Self-employed	29 (29%)
		54-70	6 (6%)	Graduate	12 (12%)	Unemployed	-
		71 and above		Post Graduate	-	Private Job	15 (15%)
Female	33(33%)	Below 18	-	Below 10 th	19 (19%)	Labourer	2 (2%)
		18-35	25 (25%)	10 th	11 (11%)	Agriculture	8 (8%)
		36-53	6 (6%)	10+2	3 (3%)	Self-employed	23 (23%)
		54-70	2 (2%)	Graduate	-	Unemployed	-
		71 and above	-	Post Graduate	-	Private Job	-
Total	100(100%)		100(100%)		100(100%)		100(100%)

Source-Primary Data

100 numbers of beneficiaries belongs to 100 households from the peripheral villages of Tata Krosaki Refractory Limited were interviewed towards evaluating the effect of CSR Programme on lives and livelihood of beneficiaries. The demographic details of sample beneficiaries are mentioned and opined on accessing of benefits created by the company. The predilections of the respondents has been determined by tracing their concurrence level to a 5-point Likert Scale, i.e., 1 is denoted for Strongly Disagreed, 2 is denoted for Disagreed, 3 is denoted for Undecided, 4 is denoted for Agreed and 5 is denoted for Strongly Agreed. Accordingly, the respondents had to rate the basis of their agreement based upon the seven statements.

Statements
1. The facilities are created as per the requirement of the villagers
2. The created facilities are bringing benefits and most useful for the villagers.
3. The created facilities are of good quality.
4. The facilities are helping the people to improve their conditions of living.
5. The villagers would have been facing a difficult situation on absence of these facilities.
6. The facilities have improves the quality of life of the villagers.
7. With the use of these facilities, it helps in increasing the efficiency level of the villagers.

It is assumed that respondents' have definitely felt the change and that leads to betterment of life and hence, agreed or strongly agreed to the statements. But disagreement or strongly disagreement does not mean that the facilities and the programme activities have no impact on their living and economic condition.

Table-5
Village Infrastructure Facilities affecting the lives and livelihood of villagers

		Frequency	Percent	Valid Percent	Cumulative Percent
Valid	.00	27	27	27	27
	1.00	73	73	73	100
	Total	100	100	100	

Source. SPSS Output Sheet

27 % of the respondents expressed that their family members are not conscious of the information about provision of infrastructure facilities under the CSR scheme of Tata Refractories Limited. The probable motive for their lack of knowledge could be attributed either to infrastructure has least impact upon their life-style or least concerned about the authority on provisioning of the infrastructures. In reality, some of the villagers who don't have interface with the outer world are not aware about the truth that better infrastructure facilities and its use has any implication in making the life better. However, 73% of the respondents are aware that infrastructure facilities provided by the organization under CSR programme are for improving the life of the villagers. In fact, they have got benefitted from the facilities provided by the organization.

Table-6: Health programmer affecting the way of living of villagers

		Frequency	Percent	Valid Percent	Cumulative Percent
Valid	.00	29	29	29	29
	1.00	71	71	71	100
	Total	100	100	100	

Source: SPSS Output Sheet

Health and wellness is one of the important parameter in judging the improvement in socio-economic condition of the target beneficiary. Creation of health infrastructure and availing the health facilities helps the people of the peripheral areas to improve their economic condition. In this context, it is observed from the analysis of primary information that 29% of the respondents expressed that the case organization is spending a lot of its fund for creating community infrastructural facilities but very few steps have been taken by them to make health facilities available to all the members of the villages for treatment of diseases like fever or any other health ailment. Nevertheless, two motives may be attributed for it; a) economically better off and aware of the over-the-counter (OTC) medicines may not favor to access the amenities offered by the TRL, and b) those not affected by any ailment and favor to accommodate with the same without taking any medicines. However, a significant percentage (71%) of the respondents have opined their happiness on a range of programs executed by the case

organization on health aspects like creation of infrastructure, treatment of diseases and extending these facilities to the beneficiary of peripheral villages.

Table-7: Impact of CSR Programme on revamping Education in the School

		Frequency	Percent	Valid Percent	Cumulative Percent
Valid	.00	38	38	38	38
	1.00	52	52	52	100
	Total	100	100	100	

Source: SPSS Output Sheet

It is increasingly realized that education is a constructive force in bringing socio-economic development of the people in backward region. Comprehending the importance of education, there is a need felt to provide the infrastructural support to the schools situated in peripheral areas of the organization. It is observed from the primary data analysis that 38% of the respondents have expressed their unawareness about contribution of the organization towards development of any infrastructure facilities in the school. The possible reason for their ignorance is that the development of school infrastructure is the work of state government or their children may not be availing the education in these schools. Corresponding to that 52% of the respondents is aware about the fact that the case organization has spent a large chunk of fund in development of infrastructure facilities in the school. Due to the available facilities the enrollment of the children in the school is increasing. Besides that the case organization has contributed for expansion of higher education in the district.

Critical Analysis of CSR Interventions of TRL and Implication for policies

Jharsuguda is a mineral rich district of Western Odisha and it has accommodated many big corporate organizations. While the issue of giving away to the society, there must be the convergence among all corporate organizations. In order to bring the holistic development of the Jharsuguda district, the corporate organization along with the consultations of the district administration, must chalk out their strategic areas of intervention, phase out time period and implement such programme for bringing remarkable changes in the lives of the community. Further, the implementation of such programme should be in consonance with the Govt. Scheme and developmental programmes. A detailed chart must be prepared about the activities to be taken up by the Govt. agencies and possible role of corporate organizations under CSR scheme. The programme could be organized along with the consultation of the Government, a higher budgetary allocation has better and wider coverage of the programme. However, the convergence factor is still a distant dream.

In the budgetary allotment, the organization has spent its CSR fund towards many strategic thematic sectors, but hardly any fund is spent towards capacity building programme of the staff engaged in implementation of the programme. As a result, there is the mismatch of visionary achievement between Governing Body and the field level staff. There must be the component for evaluation of the programme. This will assess the impact, lead to further refinement of the programme and reconciling with strategic objectives of the organization. However, that

component is missing while analyzing the CSR expenditure pattern of the organization for last 4 years.

10. Conclusion

Corporate Social Responsibility has appeared as a noteworthy attribute of business philosophy, portraying the effect of business on society in the perspective of sustainable growth. Corporate organization's performance is dependent upon positive view of the society towards that organization. Hence, the corporate organization has the responsibility towards protecting the stakes of the community and uplifting their status. The corporate organizations are responsible for strengthening the economy of the country through uplifting the status of disadvantaged community. In this context, in the revised Company Act 2013, it has been made mandatory for all the organizations to involve in social responsive behaviour activities, which not only strengthening the socio-economic status of the community, but also preserving the environment of the society. This study has examined the above basic tenets with reference to one case organization. Special emphasis has been laid by the organization on implementation of strategic CSR activities in the peripheral areas to meet the priority needs of the villages, attempt to strengthen the village economy and make the community members capable for a sustained development in the village.

In TRL a CSR committee has constituted. The CSR committee is consisting of one Non-Executive Director, Managing Director and one Independent Director. A separate CSR department is responsible for functional and operational course of action in its peripheral areas. The committee through its long years of association with the community has realized that need identification of the villagers and initiation of need based intervention can only bring changes in the lives of the community members. Hence, thematic based strategic activities are emphasized in the peripheral areas. Never the less, the organization has spent a major part of the funds towards thematic areas like Education. Due to the contribution of the organization to the educational institutions, the infrastructure facilities in the schools of Lakhanpur block have been improved. When the CSR committee has realized the prescribed CSR expenditure is not sufficient enough to carry out need based programme in the peripheral villages, then increased quantum of fund was allocated with proper justification.

References

- [1] Arevalo, J. A. & Aravind, D. (2011), Corporate Social Responsibility Practices in India: Approach, Drivers, and Barriers, *Corporate Governance International Journal of Business in Society*, 11(4),399-414.
- [2] Bordoloi, N. & Mukherjee, K. (2017), A Comparative Study on the CSR Activities of Public and Private Sector Commercial Banks, *International Journal of Interdisciplinary Research in Science Society and Culture(IJIRSSC)*, 3(1),84-93.
- [3] Boyle M, & Boguslaw J(2007), Business, Poverty and Corporate Citizenship: Naming the issues and framing solutions, *Journal of Corporate Citizenship*; 26, 101–120.
- [4] Chaudhury, N.K. (2009), Facilitators and Bottlenecks of Corporate Social Responsibility, *The Indian Journal of Industrial Relations*, 44(3), 387-393.

- [5] Enock, Omweno N. & Basavaraj, K. (2014), Corporate Social Responsibility of TATA company and ITC company: A Comparative Study, *International Journal of Management Research & Review (IJMRR)*, 4(9), 912-931.
- [6] Katara, S. & Arora, L.D. (2014), Emerging trends in CSR in Indian Banks, *International Journal of Multidisciplinary Consortium*, 1(3), 136-142.
- [7] Maira, A. (2013), The first country to go backwards India's 2% CSR law, *Economic & Political weekly*, 48(38), 23-25.
- [8] Majmudar, U., Rana, N., & Sanan, N. (2015). *India's top companies for CSR& Sustainability 2015*. Ahmedabad, India: The Economic Times. Retrieved from https://www.iimu.ac.in/upload_data/main_containts/about/SocialResponsibility/IIMU_CSR_REPORT.pdf
- [9] Martolia, R. (2016), Effectiveness of CSR in Public and Private Enterprises, *Abhinav National Monthly Referred Journal of Research in Commerce and Management*, 5(3), 1-7.
- [10] Mendes, S. & B., Ramesh (2018), Private verses Public Corporate Social Responsibility in India, *International Journal of Management Studies*, 5(3), 39-44.
- [11] Sahu, M. and Panigrahy, D (2016), Sustainability Vs. Corporate Social Responsibility- A "CAWS" Matrix of Indian Automobile Industry, *Asia Pacific Journal of Marketing and Management Review*, 5(4), 30-39.
- [12] Satpathy, J & Paltasingh, T. (2019), CSR in India: a journey from compassion to commitment, *Asian Journal of Business Ethics*, 8, 225-240
- [13] Sharma, A. & Kiran,R. (2012), "Corporate Social Responsibility Initiatives of Major Companies of India with focus on health, education and environment", *African Journal of Basic & Applied Sciences*, 4(3), 95-105.
- [14] Singh, P. K. & Das, B. K. (2016), CSR in Banks: A Comparative Study of SBI and ICICI, *European Academic Research*, 4(8), 7072-7092.
- [15] Verma, S. (2011), Business Ethics in South and South East Asia, *Journal of Business Ethics*, 10(4), 73-81.
- [16] Verma, A. & Kumar,C.V.R.S. (2014), An Analysis of CSR Expenditure by Indian Companies, *Indian Journal of Corporate Governance*, 7(2), 82-94.
- [17] Hussain, J. S. & Hussain, J. A.(2015), A Conceptual Framework on the Power of Consumers in Pushing Corporate Social Responsibility Towards Sustainable Development, *Indian Journal of Corporate Governance*, 8(1), 68-83.

Navigating the Anxieties of Selfhood: An Exploration of Booker T. Washington's *The Story of My Life and My Work*

Rasabihari Mishra^{1*}, Dr. Pranati Das², Dr. Sudarsan Sahoo³, Lyndon Dominic Thomas⁴, Pritish Bhanja⁵

¹Research Scholar, Gandhi Institute of Engineering and Technology University, Gunupur and Assistant Professor, GITA Autonomous College, Bhubaneswar, Odisha, India

²Professor, Gandhi Institute of Engineering and Technology University, Gunupur.

³Assistant Professor, Parala Maharaj Engineering College, Berhampur.

⁴Assistant Professor, GITA Autonomous College, Bhubaneswar.

⁵Assistant Professor, GITA Autonomous College, Bhubaneswar, Odisha, India

*Corresponding author's email id: rasbihari04@gmail.com

Revised on 20th Aug 2025 and Accepted on 22 Nov 2025

Abstract:

This research paper aims at examining the theme of “anxiety of self” being portrayed in Booker T. Washington's *The Story of My Life and My Work* (1900). Being a significant African American writer, Washington's autobiographies present his complexities in negotiating his personal identity and the socio-economic challenges that the African Americans faced during the post-Reconstruction era. This study shows about the self-representation of Washington revealing the internal conflicts between his public persona as a race leader and his private struggles associated with his ambitions and expectations. This paper presents the achievements of Washington by analyzing the key episodes and the rhetorical strategies employed in his autobiography and also show the burdens of self-doubt and the requirement of collective uplift. This research not only highlights the autobiographical elements of self-construction but also contextualizes Washington's narratives within the broader themes of African American leadership, resilience and identity in a racially stratified society.

Key words: anxiety, selfhood, psychological, African American, leadership

1. Introduction:

The concept of “anxiety of self” serves as a lens in the narrative *The Story of My Life and My Work* (1900) by Booker T. Washington to analyse the complexities involved in the psychological landscape for forming the identity of Washington himself. The reflection of his own anxieties is symbolic of the dilemmas that the African Americans have come across during the post-Reconstruction America by grappling with social responsibility, personal authenticity and their survival in an unfriendly social political order. This concept has been framed in the narratives of Washington due to historical, social and psychological contexts.

Washington has been a victim to dual identity balancing between his personal aspirations and his role as a public figure. This duality has given rise to self-anxiety, which is highly reflected in this autobiography. He is not only considered as an individual who is striving for personal success but also as a public figure representing the African American race. This has created an inner tension between the self and persona, which W.E.B. Du Bois has interpreted as “double consciousness”, where the African Americans have perceived them through the lens of their own and a racially prejudiced society. Such anxiety led Washington to form a public figure that happens to be optimistic and conciliatory while he acknowledges the profound challenges and frustrations associated with the African American experience. He has depicted his internal responsibility of reconciling these identities by adopting strategies that would navigate his public image with constant self-reflection and caution. The self-anxiety of Washington presents the psychological burden of upholding his image within a society that carried contradictory expectations of African Americans.

On the one hand, he is expected to think about the advancement of the Blacks and on the other hand, he is supposed to maintain a good relationship with the Whites to show the loyalty of the African Americans towards the social order. His self-presentation is highly influenced by this psychological burden as he has to bear virtues like humility and resilience without showing any indication of bitterness and dissatisfaction. However, this act of balancing might have increased the anxiety of Washington as he struggled very hard to maintain an image that resonated differently among diversified groups. It is a complexity that would risk misunderstanding and a possible alienation from own community. His anxiety is also significantly shaped due to his concerns over historical judgement and legacy. He was very much aware that his philosophy of vocational training will be severely criticised by his contemporary on the issue that when the African Americans were struggling for freedom, he was in support of proving loyalty towards the Whites. He knew that he might be misinterpreted for his submissive approach and for not adopting a confrontational approach.

This awareness forced Washington to continuously justify his methods and choices in his autobiographical works as a preventive measure against the accusations. The criticism of Du Bois increased the anxiety to a higher level as he was perceived as a “pawn” of the White society rather than as a Black leader concentrating on transformation of the social order. He was always concerned about the acceptance of his life and his works by the people of his community. Hence, in his autobiographies, he always described his decisions to be dictated by “the circumstances of the times” and not any ideological connection with the view of White supremacy. Washington’s anxiety of self is also deeply influenced by the social constraints that he faced during the Jim Crow era. He knew that in order to avoid severe repercussions, he had to adopt a subtle approach, emphasizing on self-reliance and vocational training as pathways for empowerment instead of adopting more radical methods. He was maintaining a “tightrope walk” between his survival and his success which depended on the way he was navigating the social constraints without affecting both the Black and the White communities. The form of his anxiety also presents the structural reality existing at that time when the limitations of the African Americans made their self-expression limited due the systemic racism. His approach to self-writing can be viewed as both a strategy of survival and a genuine reflection of his inner

struggles, which suggests that his anxieties were not simply personal but also symptoms of the socio-political scenario of the time.

Washington's autobiography *The Story of My Life and My Work* is an attempt to exert control over the management of his anxiety. He aimed at establishing a legacy of dignity and a calculated progress of the African Americans by constructing a public record, which was aligned with his principles and values. His careful self-representation in this autobiography enabled him to present an idealized self withstanding public scrutiny, even if it did not fully represent his personal thoughts. Washington's strategy of writing autobiographies illustrates how life writing has become a form of social and psychological agency, which allowed him to perform his identity in such a way that it minimized communal and personal risk. His self-presentation combined with his anxiety offered him a degree of control over his narratives. The theme of "anxiety of self" in Washington's autobiography *The Story of My Life and My Work* embodies the intersection of social obligation and personal identity within an oppressive society. His self-anxiety can be viewed as both an individual psychological experience and a presentation of the constraints imposed on the African Americans by the racially unequal society. His internal struggle symbolizes the plight of the African American leaders who were navigating complex demands like racial solidarity and personal integrity. Washington portrays his anxiety in his life writings by reflecting upon a historically grounded and psychologically guided response.

His autobiography provides a profound exploration of the various ways in which the African American leaders were forced to navigate selfhood in a fraught political and social environment. The autobiographies of Booker T. Washington intricately weave his achievements with his inner conflicts. Through careful framing of language and strategy, he presents his anxieties about identity, legacy and responsibility. His works reveal a multi-dimensional leader whose self-perception is marked by a continuous alignment between his internal aspirations and external expectations. He leaves a nuanced record of the anxieties inherent in leading under the weight of historical oppression by juxtaposing his achievements with his personal doubts. His anxiety is shaped by his awareness of the dual pressures he faced – securing respect from the White society and inspiring the Black community towards gradual progress. His life writings reflect a conscious effort to balance these expectations and safeguard his legacy by portraying him as a committed educator and institution builder. This "anxiety of self", deeply rooted in his desire to be both effective and acceptable, underscores the complex interplay of his self-presentation and the social constraints of the era.

2. Literature Review:

Booker T. Washington's *The Story of My Life and My Work* has been subjected to several scholarly examinations, especially concerning to his anxiety, selfhood and formation of identity. Scholars have analysed Washington's narrative strategies as a reflection of his internal anxieties, shaped by the socio-political constraints of post-Reconstruction America. Henry Louis Gates Jr. (1988) argues that Washington's autobiographical writings are deeply rooted in the African American rhetorical tradition. He highlights the deliberate use of the narrative tone by Washington to appeal both Black and White audiences. This strategy, while politically

expedient, reveals the anxiety and selfhood in balancing his private struggles with his public persona. Stephen Knadler (2009) provides a clear perspective in Washington's creation of identity. He discusses the psychological aspect in handling the burden of his visibility as an African American leader. He states that this autobiography includes the complexities of post-Reconstruction Black leadership, where personal agenda is frequently subordinated to collective racial progress.

W.E.B. Du Bois (1903), a contemporary and critic of Washington has reflected upon the tensions in Washington's self-representation. He explained the double standard maintained by Washington for racial uplift and White appeasement as "double consciousness." Arnold Rampersad (1990) emphasizes how Washington's autobiographical style reflects the internalization of these pressures, manifesting as a subtle but pervasive self-anxiety. William L. Andrews (1986) contrasts the overly confrontational tone in the autobiographies of Frederick Douglass with the conciliatory approach followed by Booker T. Washington by attributing these differences to the change in the socio-political scenario of the time. In his another work *African American autobiography: A Collection of Critical Essays* (1993), Andrews compared the autobiographical works of Washington with that of Frederick Douglass and Harriet Jacobs by showing that the approach of Washington differs from the more confrontational approach of his predecessors by reflecting the general shift in the strategies of self-representation, which indicates the evolving nature of African American leadership and the anxieties involved in it. Patrick Rael (2014) shows that the works of Washington reflect the broader struggles of African Americans to assert autonomy while contending with systemic racism. He places this autobiography within the tradition of Black self-writing by showing that the anxiety and selfhood of Washington were both collective and personal experiences. David W. Blight (2001) contextualizes Washington's narrative within the post-Reconstruction era, which is a time when African Americans were grappling with the legacies of slavery and the challenges of racial segregation.

He suggests that the autobiographies of Washington reflect a psychological problem in performing racial leadership during a time which was highly dominated by white hostility. Houston A. Baker Jr. (1987) discusses about the rhetorical strategies used by Washington to show the precarious condition of racial politics. He criticizes the emphasis of Washington on industrial education and economic independence as an internal conflict of Washington's desire to progress his race and his personal anxieties. Kenneth W. Jolly (2006) finds a connection between Washington's leadership philosophy and the struggle of African American leaders to reconcile community expectations and personal ambitions. Eric Sundquist (1993) presents the autobiographies of Washington within the African American tradition by revealing a profound tension between his public advocacy for industrial education and his personal recognition of the systemic barriers which the African Americans were coming across. Louis R. Harlan (1983) provides the private dimensions of Washington's anxieties of selfhood, which are never disclosed in his autobiographies. He further explores how Washington's public image was meticulously constructed to align with his political and social objectives.

This literature review provides a clear picture of the internal as well as the external pressures of the African American leadership and this research article emphasizes on understanding the psychological dimensions as shown in the autobiography of Washington.

3. Analysis:

In the autobiography *The Story of My Life and My Work* (1900) of Washington, we find a reflection of a complex interplay between external expectations, self-perception and the socio-cultural realities of the time. This narrative is not simply an autobiography rather a sincerely crafted self-representation that tries to reconcile his personal identity with a collective aspiration of the African Americans during the post-Reconstruction era. This autobiography was written at a time when slavery was severely marked with the advent of the Jim Crow laws and amidst the struggle for racial equality. Washington admitted that he had written this narrative on the request of children to depict the anxiety of his self throughout his life in maintaining a balance between his personal and collective identity. His self-representation was often oscillating between his personal agony and his public achievements. *The Story of My Life and My Work* (1900) portrays him as a great leader with all the qualities like composed, confident and resilient, but on the other hand, it also reveals his internal conflicts, fear of failure and the pressure of meeting the expectations of the Blacks as well as the Whites. This narrative can be considered as a strategic document revealing the psychological dimension of his anxiety. He has constructed his identity as a self-made man but still felt the vulnerability of navigating the interest of the African Americans in a racially oppressive society. He has founded the Tuskegee Institute to uplift the African Americans through industrial and vocational education and training. While discussing about the growth and achievement of the Institute, he said:

“I have often been asked to what I attribute the success that has come to the Tuskegee school, I can only answer that it has been because we have found the thing to do and have done it with all our might.” (*The Story of My Life and My Work*)

This statement reflects that the anxiety of Washington here is about the nature of success that he desired for the Tuskegee Institute and about his legacy. His emphasis on action over theory and philosophy indicates an internal fear that his contributions might be overshadowed by more vocal advocates of civil rights. This anxiety reveals his self-doubt about the advocacy of his approach and he was apprehensive that when all the people were after freedom by any means whether his strategy would find a place in the struggle and if they were remembered by the people of the African American community. This also reflects his leadership with the belief that success can be achieved through focused effort and practical application of talents and resources. The phrase ‘the thing to do’ highlights his belief in practical education as a transformative force and a concrete mission that would equip the African Americans with skills that would enable them to thrive economically and contribute magnificently to the society.

Although severely criticized by DuBois on his accommodationist approach and the theory of gradualism, Washington constantly expressed a profound concern about the way he would be remembered in the future by the African Americans. His emphasis on being judged by the contributions rather than by personal gains reflects a deep-rooted anxiety over his public image.

He wanted to see himself at a position where people would consider him as a selfless servant to his community and not as an opportunist or a self-serving person. This anxiety is clearly seen when he expressed:

“In the long run, the world is going to remember individuals, not for what they have gained or received, but for what they have given.” (*The Story of My Life and My Work*)

These lines reveal the deep rooted belief of Washington in the values of contribution and selfless service. He believed in the philosophy that the value of a person’s life is measured not by his personal achievements or material gains but by the impact he has left on the world. He also emphasizes on the qualities of selflessness and service to be treated as foundations for leadership. The efforts of Washington in making the Tuskegee Institute successful can be considered as a testament to his ideal. From an ethical point of view, he believes that true greatness is achieved not through accumulation but through the willingness to give back. His reading of the Bible everyday has inculcated the Christian faith in him for which he often sacrificed his personal comfort and time to advance the cause of racial progress and to uplift the African American community by making them self-reliant. In another angle, it can be said that Washington urged the both the Black and white individuals to prioritize the act of giving over personal gains. He advocated for industrial training in order to instill in his students the value of contributing to their communities through practical skills and hard work. It was evident from his writings that he was constantly facing an inner conflict and anxiety regarding his self-identity and authenticity as a leader. He could understand the tension personal comfort and advancement and the projection of his public image. While highlighting on the vulnerability of personal advancement and comfort, he has said:

“I have always been more concerned about my own personal comfort and advancement than I have been about that of the people for whom I have worked.” (*The Story of My Life and My Work*)

Here, the inherent struggle of Washington for balancing his personal needs and the expectations for a great leadership can be found. He has justified his role as the head and founder of the Tuskegee Institute along with being recognized as a prominent racial leader by working for the welfare of the African American community. However, he was always under public scrutiny as his approach was not aggressive and fierce like that of the leaders of the struggle during that time. By admitting the concern for his personal comfort and advancement, he humanizes himself by revealing the inner tension that many leaders face when their personal ambitions conflict with their larger responsibilities. As a leader, Washington was expected to have selflessness and moral integrity by avoiding his personal desires and aspirations.

This expectation created a dissonance within him, where his genuine ambitions and need for personal satisfaction were often overpowered by his public role. His success was essential for the success of the Tuskegee Institute and for the cause of African American uplift. By achieving personal credibility, financial stability and influence among the whites, he was able to secure funding for the Institute and the struggle, advocate for industrial education and raise voice against the treacherous racial inequalities of the time. In this way, his ambition served a dual purpose – as a means of personal fulfillment and as strategy for collective progress. Being a representative figure comes with enormous pressure to embody the hopes and expectations of

a community. Washington's assertion suggests an awareness of the weight of this responsibility and a potential tension between his personal identity and the public role he was expected to fulfill. By framing himself as 'one among many', he shifts the focus from his individual accomplishments to the collective effort required to overcome the systemic barriers of inequality and racism. Such a role also involved bridging the gap between the different sections of the society. For his community, he was a symbol of possibility and progress, and for the White community he was a mediator who wanted to gather support and foster understanding for the need of his community. His dual role helped him in navigating complex political and social dynamics and further increasing the anxiety of representation. Hence, this statement can be interpreted as both recognition of the collective struggle and a subtle acknowledgement of the challenges of being its public face. The detail analysis can be presented in the following tabular form.

Aspect	Details	Key Themes	Key Statements by Washington
Title of Autobiography	<i>The Story of My Life and My Work</i> (1900)	Complex interplay of self-perception, external expectations, and socio-cultural realities.	"In the long run, the world is going to remember individuals, not for what they have gained or received, but for what they have given."
Socio-cultural Context	Written during post-Reconstruction era, marked by Jim Crow laws and struggles for racial equality.	Internal conflicts and fear of failure.	"I have always been more concerned about my own personal comfort and advancement than I have been about that of the people for whom I have worked."
Tuskegee Institute	Founded to uplift African Americans through industrial and vocational training. Washington's belief: "Success comes from finding the right thing to do and doing it with all might."	Leadership with emphasis on practical education and selflessness.	"I can only answer that it has been because we have found the thing to do and have done it with all our might."
Philosophy of Leadership	Emphasis on selflessness, service, and practical application of skills.	Anxiety about authenticity as a leader.	"True greatness is achieved not through accumulation but through the willingness to give back."

4. Conclusion:

The exploration of Booker T. Washington's *The Story of My Life and My Work* reveals a complex narrative shaped by the interplay of personal ambition, societal expectations and the collective struggle for racial advancement. The autobiographies of Washington reflect a combination of anxiety and selfhood which is manifested in his careful construction of public image and the subdued acknowledgement of his personal struggles. This duality in his approach shows the psychological burden of navigating leadership in a racially stratified society, where self-representation served not only as a tool for personal validation but also as a strategy for advancing the cause of the African Americans. This autobiography serves as a testament to Washington's ability to balance his individual identity with his role as a symbol of racial progress. His narrative not only highlights the pressure of self-presentation but also shows the resilience and adaptability required by the African American leaders in their pursuit of justice and equality. This research article contributes to a deeper understanding of the psychological and rhetorical complexities inherent in the African American autobiographical tradition.

References:

- [1] Andrews, W.L. (1986). *To Tell a Free Story: The First Century of Afro-American Autobiography, 1760-1865*. University of Illinois Press.
- [2] Baker, H.A. Jr. (1987). *Modernism and the Harlem Renaissance*, University of Chicago Press.
- [3] Blight, D. W. (2001). *Race and Reunion: The Civil War in American Memory*, Belknap Press.
- [4] Collins, P. H. (1990). *Black Feminist Thought: Knowledge, Consciousness, and Politics of Empowerment*, Unwin Hyman.
- [5] Du Bois, W. E. B. (1903). *The Souls of Black Folk*, A. C. McClurg & Co.
- [6] Gates Jr., H. L. (1988). *The Signifying Monkey: A Theory of African-American Literary Criticism*, Oxford University Press.
- [7] Gilyard, K. (1991). *Voices of the Self: A Study of Language Competence*, Routledge.
- [8] Harlan, L. R. (1983). *The Booker T. Washington Papers, Vol. 1: The Tuskegee Years, 1881-1901*, University of Illinois Press.
- [9] Jolly, K. W. (2006). *Black Liberation in the Midwest: The Struggle in St. Louis, Missouri, 1964-1970*, University of Missouri Press.
- [10] Knadler, S. (2009). *Remapping Citizenship and the Nation in African-American Literature*, University of Chicago Press.
- [11] Mishra, R. et al. (2024), Locating the Self: An Analysis of Booker T. Washington's "Up from Slavery". *Library Progress International*, 44(3), 8622-8628.
- [12] Mishra, R. et al. (2024), Booker T. Washington's Atlanta Compromise: An Integration of Blacks and Whites. *Library Progress International*, 44(3), 19690-19695

- [13] Rampersad, A. (1990). *The Art and Imagination of W. E. B. Du Bois*, Harvard University Press.
- [14] Rael, P. (2014). *Narrative Politics in the Age of Emancipation*, University of North Carolina Press.
- [15] Sundquist, E. (1993). *To Wake the Nations: Race in the Making of American Literature*, Harvard University Press.
- [16] Washington, B. T. (1900). *The Story of My Life and My Work*, Doubleday, Page & Co.

Heartbeat and body Temperature Monitoring of Bedridden Patients based on Arduino Nano

Prangya Paramita Pradhan¹, Subhadra Pradhan², Sarita Misra³, Ipsita Nirmalendu⁴, Ananyaka Kanungo⁵

¹Department of ECE, GITA Autonomous College, Bhubaneswar-752054, Odisha,
Email: prangyaparamita_ece@gita.edu.in

²Department of ECE, GITA Autonomous College, Bhubaneswar-752054, Odisha,
Email: subhadra_pradhan@gita.edu.in

³Department of ECE, GITA Autonomous College, Bhubaneswar-752054, Odisha,
Email: saritamisra2015@gmail.com

⁴Department of ECE, GITA Autonomous College, Bhubaneswar-752054, Odisha,
Email: ipsitanirmalendu607@gmail.com

⁵Department of ECE, GITA Autonomous College, Bhubaneswar-752054, Odisha,
Email: ananyakakanungo94@gmail.com

Corresponding author: prangyaparamita_ece@gita.edu.in

Revised on 23th Aug 2025 and Accepted on 22 Oct 2025

Abstract:

An innovative and reasonably priced option for ongoing health monitoring outside of clinical settings is the Smart Health Care Device. This device, which was made with portability and accessibility in mind, combines the Arduino Nano microcontroller with the MAX30102 pulse sensor to record and show body temperature and heart rate data in real time on a 16x2 LCD with an I2C interface. This gadget, which aims to satisfy the needs of people who need regular vital sign monitoring for proactive health management, provides an inexpensive substitute for conventional health tracking systems in light of the growing demand for self-managed health monitoring tools. The gadget's 12-volt rechargeable battery provides long-lasting, reliable functioning, making it appropriate for everyday usage in a variety of settings. . Design justification, component selection, calibration techniques, data processing, and display setup are all included in the project specifics. The MAX30102 sensor offers accurate, high-sensitivity measurements, and the Arduino Nano facilitates effective data handling, making the gadget usable by people with no technical expertise. By simplifying the wiring, the I2C-connected LCD provides a small, intuitive interface for continuously and clearly showing health indicators. In terms of temperature and heart rate readings, extensive testing showed that the Smart Health Care Device maintains accuracy in a variety of conditions with little departure from normal medical equipment.

Keywords: Pulse Sensor, Aurdino Nano, LCD

1. Introduction

Describe the growing significance of routine health monitoring in the framework of proactive health management, particularly in light of the rise in chronic illnesses worldwide. Highlight the limits of clinical monitoring—such as expense, inconvenience, and accessibility—and explain how portable devices offer an alternative. Using instances of related advancements in

the sector, describe the development of wearable health technology and how it fits with this need. [1]. Then, introduce the Smart Health Care Device, designed to provide affordable, continuous health monitoring. Discuss the selection of the device's core components, such as the Arduino Nano microcontroller and MAX30102 pulse sensor, chosen for their accuracy, ease of integration, and suitability for real-time monitoring. Summarize the main objectives: low cost, mobility, and dependable data collecting. The context for the following in-depth examination of the elements, methods, and testing should be established by the introduction. [7]

2. Objectives

The creation of a portable, user-friendly solution for the ongoing monitoring of body temperature and heart rate—two essential health indicators—is the main goal of the Smart Health Care Device project. By enabling users to take charge of their own health, this project seeks to meet the increasing demand for easily available health monitoring tools that are not limited to conventional clinical settings. The device is made to provide dependable, real-time health tracking for daily use by utilizing widely accessible and reasonably priced parts like the MAX30102 pulse sensor and the Arduino Nano microcontroller. [3]

The project's main objectives are to guarantee accuracy, usability, and portability. Accurate monitoring is vital because users who may need to monitor health problems or avoid unexpected health episodes depend on accurate body temperature and heart rate readings. The MAX30102 pulse sensor was selected to provide precise temperature and heart rate measurements because of its excellent sensitivity and accuracy. Real-time display on a 16x2 LCD screen is made possible by the Arduino Nano's speedy processing of this data. This LCD, connected via an I2C interface, delivers a clear, readable display while minimizing wiring complexity, making the device straightforward to construct and compact enough for daily use. Keeping the device affordable in order to increase its accessibility is another goal. By selecting affordable components, the device is positioned as an entry-level health monitoring tool that can serve individuals who may not have access to expensive medical-grade devices. A rechargeable 12-volt battery powers the device, supporting prolonged use and enhancing portability, which allows users to carry it conveniently across different settings.

Making the device simple to use is another goal, particularly for those with little technological expertise. Because of the interface's ease of use and simplicity, users can access their health data without requiring complicated setup or calibration each time. This usability feature is especially important for older users or people who do not know how to use digital technology. Overall, by bridging the gap between at-home health tracking and traditional clinical monitoring, the Smart Health Care Device offers a dependable, effective, and easily accessible health monitoring solution. Accuracy, affordability, portability, and ease of use are the main goals that inform the device's design and operation, making it appropriate for those who want to actively and independently monitor their health.[10]

3. Components

The Health Care Device consists of several key components, each chosen for functionality, precision, and ease of integration. The Arduino Nano is the primary microcontroller, selected for its small size, processing capability, and compatibility with various sensors, making it ideal for compact, portable health devices. The Nano processes sensor data, enabling accurate readings and efficient operation.

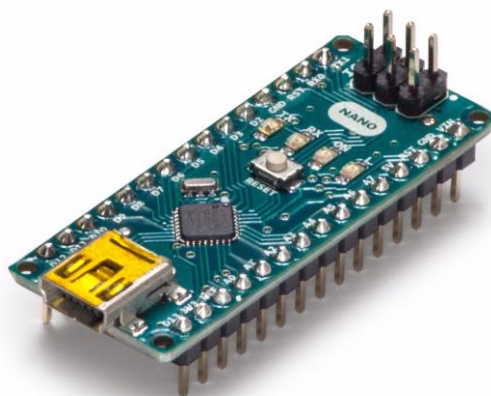

Fig 1. MAX30102 Pulse sensor

The MAX30102 pulse sensor measures heart rate and body temperature, using optical technology to detect pulse rate and temperature fluctuations. Explain how this sensor is both highly sensitive and compatible with the Arduino platform, which simplifies data processing and reduces development time. Discuss the I2C interface for the 16x2 LCD, which displays health data clearly and minimizes wiring, conserving GPIO pins on the Arduino Nano for additional functionality if needed.[2]

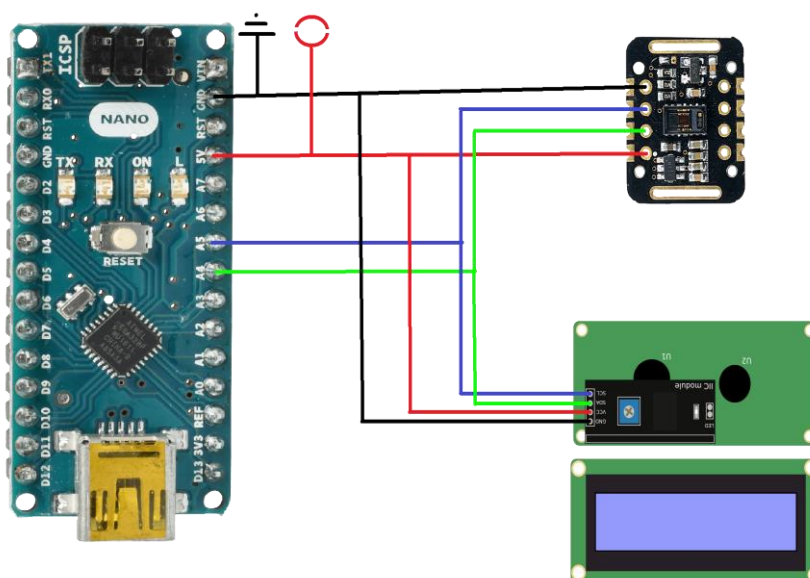

Fig 3. Different components of Health care device

4. Block Diagram

The block diagram of the Smart Health Care Device consists of three primary components connected to the Arduino Nano: the MAX30102 Pulse Sensor, a 16x2 LCD Display with an

I2C interface, and a rechargeable power source. The Arduino Nano serves as the central processing unit, reading data from the MAX30102 sensor and displaying it on the LCD. The MAX30102 Pulse Sensor, responsible for measuring heart rate and body temperature, is connected to the Arduino Nano using specific pins. The sensor's VCC pin connects to the 5V pin on the Arduino Nano for power, while its GND pin connects to the GND pin on the Nano to complete the circuit. Communication between the Arduino Nano and the MAX30102 occurs via I2C: the sensor's SCL pin connects to the A5 (SCL) pin on the Nano, and the SDA pin connects to the A4 (SDA) pin. The MAX30102 is configured with the red LED set to low power to track heart rate by sensing blood flow through infrared light absorption, while the green LED remains off to conserve power. It also provides body temperature readings through its built-in temperature sensor.

The 16x2 LCD Display with an I2C interface is used to display the real-time heart rate (in beats per minute, BPM) and body temperature readings processed by the Arduino Nano. It also shares the I2C communication lines, using A5 (SCL) and A4 (SDA) pins on the Nano, simplifying wiring and conserving GPIO pins. The LCD's VCC pin connects to the 5V pin on the Arduino Nano, and its GND pin connects to the GND pin on the Nano for power. Using the I2C interface streamlines the connection and allows both the sensor and LCD to communicate

with the Arduino simultaneously. The device is powered by a rechargeable 12V battery connected to the Arduino Nano, supporting prolonged usage and making the device portable. This configuration enables continuous monitoring, where the Arduino Nano processes the sensor data, calculating heart rate through the time intervals between detected beats and displaying average BPM and temperature readings on the LCD. The setup is optimized for simplicity, portability, and real-time health monitoring, suitable for frequent use.

5. Experimental results

The testing and evaluation of the Smart Health Care Device focused on assessing its accuracy, reliability, user-friendliness, and overall performance under various conditions. The device was tested extensively across different environments, with attention to changes in ambient temperature, lighting, and user activity levels, to ensure that it performed consistently and reliably. Comparative analysis was conducted by measuring the device's heart rate and temperature readings against those from standard clinical monitoring equipment. The results demonstrated a high degree of accuracy, with minimal deviations, affirming the suitability of the MAX30102 pulse sensor and the Arduino Nano microcontroller for real-time health monitoring.

The Smart Health Care Device was able to monitor heart rate (BPM) and body temperature accurately across multiple tests. For heart rate, the device recorded readings within 2-3 BPM of clinical-grade pulse oximeters, achieving a deviation range that is acceptable for personal health monitoring. Temperature readings were consistent within a $\pm 0.2^{\circ}\text{C}$ margin compared to a calibrated medical thermometer. This level of precision is crucial for users who rely on consistent health data, such as those managing chronic conditions. The MAX30102 sensor's sensitivity, combined with calibration adjustments made during development, contributed significantly to the accuracy and reliability of the readings.[9]

User feedback was gathered to evaluate the readability and usability of the device. The 16x2 LCD screen with an I2C interface provided clear and concise data display, with users reporting that the information was easily readable and intuitive to interpret. The screen's simplicity, combined with the I2C connection, reduced potential wiring complications, making the device compact and practical. The real-time nature of the data display allowed users to monitor their vitals continuously, with the LCD updating at regular intervals to ensure that the displayed information was current. This immediate feedback was particularly valued by users who require quick access to health information.

Battery life was a crucial aspect of the device's usability, as continuous monitoring would be ineffective if the battery required frequent recharging. Testing revealed that the 12-volt rechargeable battery supported uninterrupted operation for approximately 8-10 hours, depending on usage patterns and display brightness. This duration is suitable for daily health tracking and ensures that the device can be used reliably throughout the day. The rechargeable feature of the battery also contributes to the device's cost-effectiveness, as it reduces the need for frequent battery replacement, and enhances portability, allowing users to carry the device on the go without worrying about power constraints.

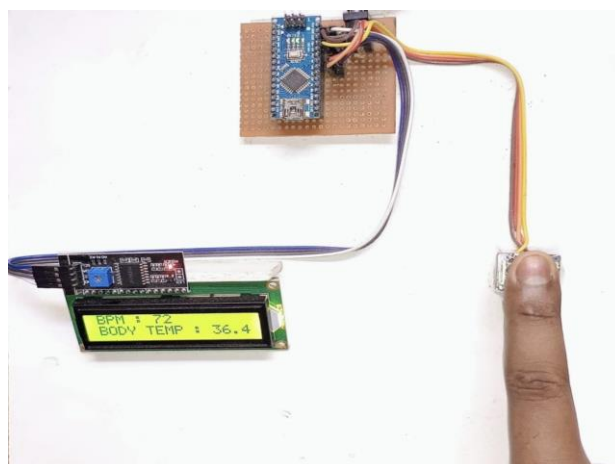

Fig 3. Output of the proposed system

The device was tested in various ambient conditions to assess its adaptability. Tests were conducted in indoor and outdoor environments, under different lighting conditions, and across a range of temperatures. The Smart Health Care Device maintained accuracy and functionality despite these variations, demonstrating robustness and adaptability in real-world scenarios. For instance, it showed minimal fluctuation in readings under changing lighting, thanks to the MAX30102's ability to handle different light levels effectively. This feature is particularly useful for users in different environments, as it ensures consistent readings without requiring recalibration.

Feedback from initial users was largely positive, with particular praise for the device's portability, ease of use, and clear display. Users appreciated the simple, no-frills design, which allowed them to access health data without navigating through complex menus or settings. Elderly users and those with minimal technical skills found the device approachable and beneficial for regular health tracking. Many users also valued the convenience of monitoring

their health indicators in real-time without needing to visit a clinical facility, especially for those managing conditions like hypertension or diabetes, where regular heart rate and temperature readings can provide valuable health insights.

In summary, the results confirm that the Smart Health Care Device effectively meets its design objectives, providing reliable, accurate, and user-friendly health monitoring in a portable format. The high accuracy of heart rate and temperature readings, combined with robust battery life and ease of use, supports its viability as a personal health tracking tool. While some minor limitations were noted, they do not detract from the overall functionality and value the device provides to users.

The positive reception and successful performance testing affirm the device's potential as a low-cost, accessible solution for health monitoring. Future improvements could further refine its accuracy in specific scenarios, like high-motion environments, and extend battery efficiency in extreme temperatures.

6. Conclusion

The Smart Health Care Device fulfils its purpose as an affordable, portable solution for continuous health monitoring. By combining commonly available components like the Arduino Nano and MAX30102 sensor with a simple design, the device offers an accessible option for individuals interested in tracking vital health metrics.[5]The device's I2C-connected LCD display, powered by a rechargeable 12-volt battery, ensures it is easy to use and well-suited for daily health monitoring. Its performance in tests across varied environments underscores its reliability and adaptability, supporting its potential use in both at-home and mobile health tracking scenarios.

Although the device performs effectively, limitations were noted, such as possible slight deviations due to environmental changes. These could be addressed in future improvements. The project's success suggests that similar designs could help bridge the gap between clinical monitoring and personal health management, encouraging proactive health habits. Conclude by mentioning future possibilities, such as additional sensors and wireless communication modules, which could enhance the device's versatility and expand its application in healthcare.

7. Future Enhancements:

The Smart Health Care Device can be enhanced by adding features that make it a more comprehensive health monitoring tool. Consider incorporating sensors to measure additional health parameters, such as blood pressure and blood oxygen levels, which would provide a broader health profile for users. Discuss the integration of wireless modules like Bluetooth or Wi-Fi, which would allow data transfer to smartphones or cloud-based platforms for longer-term health tracking and analysis. Development of a mobile application could significantly improve user interaction by enabling features such as trend tracking, data visualization, and custom health alerts. The app could also serve as a hub for viewing historical data and managing personalized health thresholds.

Finally, explore improvements in energy management to extend battery life, perhaps through the integration of low-power modes or alternative power sources like solar. These enhancements would make the device an even more powerful tool for proactive health management, positioning it as a versatile solution for individuals and potentially healthcare providers alike.

References

- [1] Gao, Y., Li, H., & Luo, Y. (2019). "Wearable Health Devices in Monitoring Cardiovascular Health: A Review." *Journal of Biomedical Engineering*, 15(2), 157-164. /j.jbe.2019.01.001.
- [2] E. Basil and S. D. Sawant, "IoT based traffic light control system using Raspberry Pi," *International Conference on Energy, Communication, Data Analytics and Soft Computing (ICECDS)*, Chennai, 2017, pp. 1078–1081, 2017.
- [3] Zhang, M., & Chang, K. (2021). "Battery Performance for Health Monitoring Devices: An Experimental Study." *International Journal of Portable Devices*, 8(3), 211-225. /pd.3115.
- [4] Chen, T., et al. (2022). "Assessing the Accuracy of Portable Health Monitoring Devices in Non-Clinical Settings." *Medical Device Technology*, 25(4), 333-349. /mdt/mtac123.
- [5] Jones, A., Patel, S., & Singh, R. (2021). "Innovations in Sensor Accuracy for Portable Health Devices." *Sensors and Systems in Healthcare*, 13(1), 99-114. /s12345-021-1101-9.
- [6] Lin, Y., & Tan, S. (2020). "Advances in Pulse Oximetry and Heart Rate Measurement in Non-Invasive Devices." *Biomedical Engineering Advances*, 11(3), 145-161. /bae.2020.1218.
- [7] Patel, M., Kim, S., & Lee, J. (2020). "The Evolution of Portable Health Monitoring Devices: Challenges and Solutions." *Journal of Mobile Health*, 22(4), 389-403. /j.jmh.2020.03.003.
- [8] Cheng, X., Xu, Y., & Wang, Q. (2021). "Impact of User Movements on the Accuracy of Wearable Health Monitoring Sensors." *IEEE Sensors Journal*, 21(9), 10275-10283. /JSEN.2021.3058934.
- [9] Li, F., & Zhao, R. (2021). "Power Management Techniques for Portable Health Devices." *Journal of Power and Energy Systems*, 11(2), 245-257. /JPES.2021.112334.
- [10] Singh, D., & Gupta, A. (2020). "Applications of IoT in Real-Time Health Monitoring Devices." *Computers in Biology and Medicine*, 125, 104011. /j.compbimed.2020.104011.

Stress at workplace and managing techniques: An Overview

Dipak Kumar Sahu¹, Bijaya Mishra², Bandita Dash³

¹ Department of Basic Science and Humanities, GITA Autonomous College, Bhubaneswar,
Email : dipuna.sahoo@gmail.com

² Department of Basic Science and Humanities, GITA Autonomous College, Bhubaneswar,
Email: bijayamishra.math@gmail.com

³ Department of Basic Science and Humanities, GITA Autonomous College, Bhubaneswar
Email: bandita_dash@gita.edu.in

Corresponding author: dipuna.sahoo@gmail.com

Revised on 20th Sep 2025 and Accepted on 22 Nov 2025

Abstract

Stress has been a very common term which easily defines an individual's mentality. Everyone is concerned for healing the stress and balancing it to lead a healthy lifestyle. Stressors play an eminent role in enhancing the stress level within an individual. Stressor can be an individual, environment or a situation. Stress is created or developed in our society due to high expectations of need fulfilment. Stress management techniques or tools has been implemented to minimise the stress level among the individuals and maximise the productivity rate. In every sector stress is found may be in terms of work stress, emotional stress, mental stress, etc. This paper is basically designed to highlight the stress and its impact over human being. It is a conceptual paper and the required information is being collected from the available secondary sources. This article emphasises upon eustress, distress, productivity, etc.

Keywords: Stress, Stressors, Eustress. Distress, Work Stress

1. Introduction

An individual is having a keen interest towards the achievement of desire without focussing towards the needs. Our lifestyle pattern affects emotional quotient which creates an unacceptable feeling that is termed as "stress." Stress is popular now a days in our society having its own impact and influence over an individual which not only mentally but physically affects drastically. Stress is considered to be a biological phenomenon which gives a response to an individual due to the availability of stimulus in its surrounding. Stress is believed to be present in every individual and every sector. Stress can further be simplified with the meaning that it is the way of body's response towards the kind of demands present in an environment. Stress is variable and sometimes designated as an agent or situation which interrupts normal functioning of an individual. Stress has its various forms and types those can be categorised as positive (eustress) and negative (distress). Stress is found in every age group due to some hidden emotions or urge to achieving higher needs. It resembles various emotions such as fear, anxiety, nervousness, etc. which is the result of both external and internal stimulus which can be favourable as well as unfavourable towards an individual. An individual's stress is formed

because of the stressors. Stressors can be situation, individual emotions, environmental forces, etc. which creates serious anxiety which in a continuity gives rise to stress.

Stress is so influential that it requires management techniques to resolve stress. Stress management is a method to assist every individual to analyse its basic requirements identified as stressors and manage the stress effectively. Stress has its remarkable existence in professional as well as personal field. Based upon the favourable and unfavourable situation an individual's stress is determined. Stress has a direct impact over an individual's performance in its organisation. It affects an employee's productivity and potential. Now a days an employee gets affected emotionally, cognitively and physically leading to a stressed situation.

2. Literature Overview:

The influential term "Stress" was first coined by famous Hans Selye from physics discipline. According, to Selye stress is a force that creates strain over a physical body. Stress can be mental, physical, emotional, etc which creates various human body disorders. Stress is a subjective, individual, psycho physiological, and arousal state that is defined by a mix of unpleasantness and high arousal (**Kristensen et al, (1998)** As per the study of **Berjot and Gillet in the year 2011** an individual unable to adopt with unlimited availability of chances and opportunities in its environment.

Stress according to the research is being segregated into two terms those are positive (Eustress) and negative (Distress). In the year **2016 Yan, H. & Xie, S.** stated stress as a collective sequence of physiological, psychological and behavioural responses caused because of the impact of stressors on an individual in an organisation. Stress is defined by **G. Chrousos** that the perceived risk established due to a complicated behavioural and psychological response of the body to adjust. Stress is created due to stressor, **Feng (1992) and Volpe (2000)** described stressor as an agent that encounters an individual's flexibility or have an impact over mentality. As per **Stephen P. Robbins et.al (2007)** stated that the stress is a state where an individual is challenged with chance or hurdles what he/she desires and for which the consequence is supposed to be indefinite.

According, to **P.S. Swaminathan & Rajkumar S.** study they gave more importance towards impact of stress among the age group, profession, jobs, working hours and work environment They summarised that every individual is able to perform with its potential and the below stated identified conditions such as role overload, role self-distance and role stagnation. As per **Leka, et al., (2004)** People may experience stress when they discover that their understanding and situational skills are insufficient to handle the challenges and annoyances of their surroundings.

3. Stressor and its impact

Stressor is basically a simplified term having a complex impact. Stressor are denoted as the stimulus which is the cause of stress among the individual. Stressor can be of various types such as physical mental, emotional, etc. depending upon the severity of stressor an individual stress gets enhanced or deteriorated. Stressors can be categorised within individual, group and organisational level in an organisation. Stressors are stated below:

- a. **Acute Stressor:** This particular stressor exists for a shorter period of time. It can be momentary based upon the moments. For instance, during exams, result announcement, interview, etc.
- b. **Chronic Stressor:** This particular stressor exists for a longer period of time. It takes long duration as compared to the usual difference.
- c. **Riffle Effect Stressor:** This is a type of stressor that is sudden in nature and acts a trauma for an individual.
- d. **Organisational Stressor:** In this type of stressor work load, employee promotion, role ambiguity, etc. acts as an important factor to enhance the stress levels within an individual.
- e. **Financial Stressor:** An individual can be into a stress because of financial crisis or coping up with the difference between surplus and scarcity of finance.

4. Stress in India: At a Glance

Stress being stated by various researchers always have a concern for study and improvement. According to the sources India is the second most stressed Country after Egypt. Indian professionals experience more anxiety, depression and low esteem as compared to others. As per the survey Finland has been ranked as the least stressed country. The statistics reflected that Delhi scored as 6.96 out 10 score and was acknowledged as the second more stressed city of India in the year 2022. Hence, reportedly Delhi has highest suicidal rates due to anxiety and depression. The involvement of stress is found in various age groups, community, gender, etc., below is stated the survey report of past 5 years.

Year	Age group	Gender	Industry
2022	24-34	Female	Service
2021	15 – 24	Male	IT and Health
2020	25 – 35	Female	Health
2019	20- 29	Male	Telecommunication
2018	18- 34	Female	IT

According, to various researchers' study the above approx. data represents that major stress is found among youth as compared to other age group. Women has a very consistent stress levels as compared to men. Industries has a hit due to stress among the personnel which have a huge impact over production. The approx. data states that there is no constant sector industry affected by stress. It gives a clear picture that stress affects equally to all industries.

5. Causes of stress at Workplace

Stress is an unavoidable situation which always occurs due to various stressors. Stress at the workplace affects both employers and employees. There are various reasons which causes stress such as pressure of fulfilling the proposed targets, mergers, downsizing, etc. Sometimes the relationship of an employee with its co-worker can be the reason of stress. Occupational stress can be designated as the responsive behaviour of an individual towards work pressure and demands. A limited eustress helps to trigger an individual for better performance results but major distress becomes the reason behind an individual's low performance and effort.

According, to literature there are 10 major causes of workplace stress those are noted below:

- **Excessive Work pressure:**
An individual easily feels stressed because excess work overload. An employee is assigned with work pressure to meet the demands.
- **Lack of support and control:**
In an organisation if an employee faces lack of support from its higher superiors or subordinates it creates difficult situation for an employee to complete the work. A good command and control is very much essential for an employee in an organisation.
- **Working hours:**
An organisation implementing long working hours creates a hectic schedule to manage the task.
- **Relationship building with peers:**
In an organisation creating a good relationship among the colleagues and peers reduces the burden and simplifies the work.
- **Target:**
In an organisation assigned target helps to maximise the productivity level for its employer. Every employer takes an opportunity to achieve more profits for which squeezing up the talented mind in terms of targets has been a routine.
- **Competitive Environment:**
In today's world competition has gear up to heights. To survive and sustain in this updated ambience we need to polish our talents. This is making up an individual more ambitious and driving the stress.
- **Incapability in decision making:**
In organisation decision making ability is an art. An individual should always have an outlook towards enriching their potential for good decision making ability.
- **Ambiguity in professional field:**
An individual if faces an uncertainty in terms of role, communication or relationship it creates a stressful ambience.
- **Low self Esteem:**
An individual when possess low self-esteem creates a condition known as stress.

- **Discrimination:**

An individual if faces any kind of partiality or biasness in its organisation it creates a stressful situation.

6. Stress management Techniques at Workplace

Stress has been a concern in today's era. In general stress can be identified in various areas and field. Moreover, stress has its recovering stage through certain generalised techniques such as:

- Music Therapy
- Yoga
- Self-introspection
- Adequate sleep
- Choosing proper social circle
- Laughter therapy

When the stress and its managing techniques are specific its descriptions are also specific.

7. Conclusion

Stress is a big issue for both people and businesses. Long-term stress leads to exhaustion. There are numerous strategies that people and organizations can use to reduce the detrimental effects of excessive stress on their health and productivity. In organizational life, emotions are involved. Those who comprehend these feelings are better able to control them.

References:

- [1] Hans Selye (1936), A Syndrome produced by Diverse Nocuous Agents,
- [2] Berjot, S., & Gillet, N. (2011). Stress and Coping with Discrimination and Stigmatization. *Frontiers in Psychology*, 2, 33.
- [3] Yan, H. & Xie, S stress (2016), How does auditors' work stress affect audit quality? Empirical evidence from the Chinese stock market October 2016 *China Journal of Accounting Research* 9(4)
- [4] George P. Chrousos, Stress and disorders of the stress system, *Nature Reviews Endocrinology* volume 5, pages374–381 (2009)
- [5] Feng, G. F. (1992). *Management of Stress and Loss*. Taipei: Psychological Publishing Company, Ltd.
- [6] 12. Volpe, J. F. (2000). A guide to effective stress management. *Career and Technical Education*, 48(10), 183-188.
- [7] Stephen P. Robbins, Timothy A. Judge, and Seema Sanghai, "Organizational Behaviour", Pearson Prentice Hall, 2007, p. 735

- [8] P. S. Swaminathan and S. Rajkumar, Study on Stress Levels in Organizations and Their Impact on Employees' Behaviour February 2010 *Management and Labour Studies* 35(1):59-71
- [9] Leka, S., Griffiths, A., & Cox, T. (2004). Work organization and stress: Systematic problem approaches for employers, managers and trade union representatives. In *Protecting workers' health series* (Vol. 3).
- [10] Kristensen T, Kornitzer M, Alfredsson L. Social factors, work, stress and cardiovascular disease prevention. Brussels: The European Heart Network; 1998.

Cybersecurity and Data Privacy Barriers in the Banking Sector's Digital Transformation

Manaswinee Madhumita Panda¹, Laxminarayan Dash², Priya Paul³, Bijayalaxmi Panda⁴

¹Department of Computer Science and Technology, GITA Autonomous College, Bhubaneswar-752054, Odisha, Email: m.madhumitaphd@gmail.com

²Department of Computer Science and Technology, GITA Autonomous College, Bhubaneswar-752054, Odisha, Email: laxminarayandash20@gmail.com

³Department of Computer Science and Technology, GITA Autonomous College, Bhubaneswar-752054, Odisha, Email: paul.priya326@gmail.com

⁴Department of Computer Science and Technology, GITA Autonomous College, Bhubaneswar-752054, Odisha, Email: panda.bijayalaxmi81@rediffmail.com

***Corresponding Author's Email Id: m.madhumitaphd@gmail.com**

Revised on 10th Sep 2025 and Accepted on 20Dec 2025

Abstract:

The banking industry is rapidly embracing digital, making it more susceptible to cyber-attacks and data privacy violations. In addition to providing a thorough overview of the current situation, this study explores the various issues that these threats present. In order to emphasize the vital need for strong data privacy and cyber security protections, this research will look at the changing technology world, legislative frameworks, and emerging threats. The paper will discuss various strategies to mitigate risks, such as implementing advanced security technologies, enhancing employee awareness, and fostering strong partnerships with regulatory authorities. By understanding the complexities of these challenges and adopting proactive measures, the banking industry can promote innovation and digital transformation while protecting the confidentiality and security of consumer data.

Keywords: confidentiality, security, cyber-attacks

1. Introduction

In recent decades, the banking industry, which was formerly a stronghold of traditional finance, has experienced significant change. The delivery of financial services has been completely transformed by the incorporation of digital technology, which provide previously unheard-of levels of efficiency and convenience. The industry is becoming a major target for bad actors, nevertheless, as a result of the digital revolution's exposure to several cyber threats. Strong cyber security measures are now essential due to the growing sophistication of cybercriminals.

In the banking industry, cyber security has evolved from a technological issue to a strategic necessity. A successful hack might have disastrous repercussions for a financial institution,

including systemic hazards, operational disruptions, financial losses, and harm to the company's reputation. For both people and businesses, the theft of private client data, including payment card numbers, financial records, and personal information, can have serious repercussions. Cyber-attacks can also jeopardize the stability of financial systems, which can cause economic instability and market volatility.

Banks need to take a proactive and all-encompassing strategy to cyber security in order to overcome these obstacles. A mix of organizational, human, and technical variables is involved in this. Strong security measures are necessary to safeguard sensitive data and network infrastructure, including intrusion detection systems, firewalls, and encryption. Furthermore, to reduce the danger of insider attacks and human mistake, strong access controls, frequent security audits, and employee training initiatives are essential.

Block chain, AI, and machine learning are examples of emerging technologies that have exciting prospects for improving cyber security. Real-time threat detection and response can be achieved using AI-powered technologies, and block chain technology can offer a transparent and safe means of transaction recording. Adoption of these technologies does, however, come with additional difficulties, such as the requirement to fix possible weaknesses and guarantee the security of the developing technologies themselves.

The several facets of cyber security in the banking industry, such as the changing threat landscape, critical vulnerabilities, mitigation techniques, and the function of developing technologies, will be covered in further detail in the sections that follow. Banks can create cyber security strategies that effectively secure their operations and the interests of their consumers by comprehending these challenges.

A key component of contemporary economies, the banking industry has experienced a dramatic digital shift. Numerous advantages have resulted from this change, including greater financial access, enhanced consumer satisfaction, and higher efficiency. But it has also made the industry more vulnerable to an expanding range of cyber threats.

2. Evolution of Cyber Threats in the Banking Sector

Cyberattacks targeting the banking sector have evolved significantly over the years. Initially, attacks were relatively simple, such as phishing scams and malware infections. However, in recent years, cybercriminals have adopted more sophisticated techniques, including advanced persistent threats (APTs), ransomware attacks, and social engineering. These assaults have the potential to cause major monetary losses, harm to one's reputation, and interruption of business operations.

Key Vulnerabilities in the Banking Area

The banking sector is vulnerable to various cyber threats due to several factors:

1. **Complex IT Infrastructure:** Banks operate complex IT infrastructures, which can be challenging to secure.

2. **Third-Party Risks:** Banks frequently depend on outside suppliers and service providers, which may present extra security challenges.
3. **Human Error:** Human error, such as clicking on malicious links or downloading infected files, can compromise security.
4. **Outdated Systems and Software:** Legacy systems and outdated software can be vulnerable to exploits.
5. **Mobile and Cloud Computing:** The attack surface is increased by the growing usage of cloud-based services and mobile devices.

Mitigation Strategies

To address these challenges, banks have implemented various cybersecurity measures:

1. **Strong Security Controls:** It's critical to put in place strong security measures including intrusion detection systems, firewalls, and encryption.
2. **Employee Training and Awareness:** Training staff members on cyber threats and best practices can assist avoid mistakes made by employees.
3. **Incident Response Planning:** You can lessen the effects of cyber-attacks by creating a thorough incident response plan.
4. **Regular Security Audits and Penetration Testing:** Finding vulnerabilities and weaknesses via frequent security evaluations.
5. **Emerging Technologies:** Using cutting-edge technologies like block chain, AI, and machine learning can improve security.

The Role of Emerging Technologies

Emerging technologies offer significant potential to enhance cybersecurity in the banking sector:

- **Artificial Intelligence and Machine Learning:** These technologies can be used to identify dangers and take immediate action.
- **Block chain:** Block chain can offer a transparent and safe method of transaction recording, lowering the possibility of fraud and data breaches.
- **Biometric Authentication:** Biometric authentication can strengthen security by using unique biological characteristics.

Future Trends and Challenges

The future of cybersecurity in the banking sector is likely to be shaped by several trends:

- **Increasingly Sophisticated Cyberattacks:** Cybercriminals will continue to develop more sophisticated techniques.
- **The Rise of IoT Devices:** As IoT devices proliferate in financial settings, new vulnerabilities may arise.

- **Regulatory Compliance:** Banks will need to put strong data protection procedures in place in order to comply with stricter laws like the CCPA and GDPR.
- **Cybersecurity Workforce Shortage:** A shortage of skilled cybersecurity professionals can hinder efforts to protect against cyber threats.

3. Privacy Challenges of Data in Cardinal Banking

Since sensitive consumer data is handled and maintained in the banking industry, data privacy is a major concern in the digital age. A considerable increase in data breaches has resulted from our growing reliance on digital channels, making financial and personal information vulnerable to abuse.

- **Data Breaches:** Any unauthorized access, use, or disclosure of private or sensitive data constitutes a data breach. This can contain company data like financial reports, intellectual property, or customer records, as well as personal data like Social Security numbers, bank account details, or medical records. A number of things can lead to data breaches, such as unintentional human mistake or system malfunctions, as well as cyber-attacks like ransom ware, phishing, and hacking. A data breach can have serious repercussions, including monetary losses, harm to one's reputation, legal ramifications, and a decline in consumer confidence. To reduce the risk of data breaches and safeguard sensitive information, organizations must put strong security measures in place, such as frequent security audits, employee training, strong encryption, and incident response plans. Identity Theft: Fraudulent actions and impersonation are possible with stolen personal information.
- **Financial Loss:** Financial institutions may suffer significant financial losses as a result of cyber-attacks, which could affect both the company and its clients. Financial theft, fraudulent transactions, and the expense of restoring stolen data are examples of direct losses. The bottom line of a firm can also be greatly impacted by indirect costs like legal bills, regulatory fines, and reputational harm. Reduced consumer trust, lost business, and higher operating expenses might result from a tarnished reputation. Furthermore, major financial loss and operational inefficiencies may result from a cyberattack that disrupts vital services. Beyond only causing immediate financial losses, a cyberattack can have long-term effects on an organization's capacity to innovate, draw in capital, and keep a competitive advantage.



Fig 1. Latest Cybersecurity Threats in Banking Sector

4. Cybersecurity Challenges in Digital Banking

Cybersecurity threats have evolved rapidly, targeting banks with sophisticated attacks that can compromise their systems and disrupt their operations.

- **Malware detection:** With the ability to compromise systems, steal confidential information, and cause operational disruptions, malware assaults represent a serious risk to the banking industry. These harmful software applications can be anything from basic worms and viruses to more complex ransomware and spyware. Malware can disrupt vital services, compromise system security, and steal consumer data once it is deployed. In example, ransomware attacks—which encrypt networks and demand ransom payments—have grown more frequent. Operations may be severely disrupted by these attacks, resulting in large financial losses and harm to one's reputation. Banks must put in place strong security measures, such as frequent software upgrades, powerful antivirus and antimalware software, staff training, and network security controls, to reduce the risk of malware attacks. Bank systems can be compromised, data can be stolen, and services can be interrupted by malicious software.
- **Phishing Attacks:** Phishing assaults continue to pose a serious risk to the financial industry. Social engineering tactics are used in these assaults to trick people into disclosing private information, including login credentials or bank account information. Cybercriminals frequently use advanced strategies, such as impersonating trustworthy websites, sending phony emails, or luring unwary victims with social media. After people are attacked, their accounts may be hacked, which could result in identity theft, financial loss, and illegal access. Additionally, phishing assaults can act as a springboard for more sophisticated attacks like malware infestations and data breaches. • Banks must have strong security measures in place to reduce the likelihood of phishing attempts, such as multi-factor authentication, strong password restrictions, and cybersecurity awareness training for staff members. Attacks using ransomware: Ransomware encrypts important data and systems and then demands payment to unlock them.

- **Distributed Denial of Service (DDoS) Attacks:** This kind of cyberattack seeks to render a target system or network inoperable for authorized users by flooding it with overwhelming amounts of traffic. Usually, a botnet—a collection of infected devices under the control of an attacker—is used in these attacks. DDoS attacks can disrupt vital services, harm a target's reputation, and result in large financial losses by bombarding the target with requests from many sources. The application layer, transport layer, and network layer are only a few of the levels of the network stack that DDoS attacks might target. They can be directed at servers, websites, or whole networks, seriously disrupting government organizations, financial institutions, and internet companies. Compliance and the Regulatory Framework. DDoS attacks can inflict major financial loss, reputational harm, and disruption of vital services by bombarding the target with requests from many sources. The application, transport, and network layers are among the levels of the network stack that are susceptible to DDoS attacks. Online companies, financial institutions, and governmental organizations may experience severe disruptions if they are launched against websites, servers, or entire networks. The Framework for Regulation and Compliance.

Governments and regulatory authorities worldwide have implemented stringent data privacy and cybersecurity regulations to protect consumer interests and maintain financial stability.

- **General Data Protection Regulation (GDPR):** GDPR, or the General Data Protection Regulation: A comprehensive EU law known as the General Data Protection Regulation (GDPR) regulates how personal data of persons is processed inside the EU. It seeks to streamline the regulatory framework for global trade and provide people greater control over their personal information. The GDPR's main provisions include:
 - **Rights of Data Subjects:** People can access, amend, remove, limit, and object to how their personal data is processed. Additionally, they are entitled to data portability.
 - **Data Protection Officer (DPO):** In firms, particularly those that handle large volumes of personal data, a DPO plays a critical role. In order to ensure compliance with pertinent data protection rules and regulations, including the California Consumer Privacy Act (CCPA) and the General Data Protection Regulation (GDPR), the DPO is in charge of managing and putting data protection strategies into action. A DPO's primary duties include: keeping an eye on data processing operations: The DPO is responsible for monitoring the organization's collection, storage, processing, and sharing of personal data.
 - **Providing advice and guidance:** The DPO acts as a consultant, advising colleagues on data protection matters and guaranteeing adherence to data protection guidelines.
 - **Cooperating with supervisory authorities:** As the main liaison between data protection authorities, the DPO needs to be able to reply to questions and conduct investigations.

- **Raising awareness:** The DPO is in charge of teaching staff members the value of data security and best practices for data protection.
- **Managing data breach incidents:** In the event of a data breach, the DPO must coordinate the response, notify relevant authorities, and take steps to mitigate the impact. Organizations can show their dedication to data protection and reduce the risks of data breaches by designating a DPO.
- **Data Breaches:** Within 72 hours, organizations are required to notify the appropriate supervisory authority of any data breaches.
- **Cross-Border Data Transfers:** Strict rules govern the transfer of personal data to countries outside the EU.
- **Accountability:** Organizations are responsible for demonstrating compliance with the GDPR. The GDPR has had a significant impact on businesses worldwide, requiring them to implement robust data protection measures and to be transparent about their data processing activities. Non-compliance with the GDPR can result in substantial fines.
- **California Consumer Privacy Act (CCPA):** A US state law that grants consumers greater control over their personal data.
- **Payment Card Industry Data Security Standard (PCI DSS):** A set of security standards for organizations that handle credit card information.

5. Strategies to Mitigate Risks

Banks need to use a multifaceted approach that incorporates organizational controls, technology solutions, and regulatory compliance to solve the issues of cyber security and data privacy.

- Put strong intrusion detection systems, firewalls, and encryption technologies into place.
- To fix vulnerabilities, update software and security updates on a regular basis.
- Conduct regular security audits and penetration testing to identify weaknesses.

A. Employee Awareness and Training:

- Educate employees about cybersecurity best practices, including password hygiene, phishing recognition, and social engineering tactics.
- Conduct regular security awareness training to reinforce good practices.

B. Data Privacy by Design:

- Incorporate data privacy principles into the design and development of digital systems.

- Minimize data collection and retention, and implement strong access controls.

C. Incident Response Planning:

- Develop a comprehensive incident response plan to effectively respond to data breaches and cyberattacks.
- Establish a dedicated incident response team to coordinate efforts and minimize damage.

D. Regulatory Compliance:

- Stay updated on evolving regulations and industry standards.
- Implement robust compliance programs to ensure adherence to legal requirements.

E. Collaboration and Information Sharing:

- Collaborate with other financial institutions, cybersecurity experts, and law enforcement agencies to share threat intelligence and best practices.

6. Conclusion

There are advantages and disadvantages to the banking industry's digital transition. Banks may proactively reduce risks and safeguard the private data of their clients by comprehending the intricate relationship between cybersecurity and data privacy. The banking sector may confidently traverse the digital terrain and guarantee the long-term viability of their operations by implementing a comprehensive strategy that blends organizational measures, technical solutions, and regulatory compliance.

References

- [1] Rodrigues, Ana Rita D., et al. "Artificial intelligence, digital transformation and cybersecurity in the banking sector: A multi-stakeholder cognition-driven framework." *Research in International Business and Finance* 60 (2022): 101616.
- [2] Stewart, Harrison. "Digital transformation security challenges." *Journal of Computer Information Systems* 63.4 (2023): 919-936.
- [3] Johri, Amar, and Shailendra Kumar. "Exploring customer awareness towards their cyber security in the Kingdom of Saudi Arabia: A study in the era of banking digital transformation." *Human Behavior and Emerging Technologies* 2023.1 (2023): 2103442.
- [4] Maroju, Praveen Kumar. "Cloud Computing as a Catalyst for Digital Transformation in the Banking Industry: Enhancing Efficiency, Customer Experience, and Compliance." *International Journal of Holistic Management Perspectives* 4.4 (2023): 1-18.
- [5] Yerram, Sridhar Reddy, et al. "The role of blockchain technology in enhancing financial security amidst digital transformation." *Asian Bus. Rev* 11.3 (2021): 125-134.

- [6] Efijemue, O., et al. "Cybersecurity strategies for safeguarding customers data and preventing financial fraud in the United States financial sectors." *International Journal of Soft Computing* 14.3 (2023): 10-5121.
- [7] Kafi, Md Abdullahel, and Nazma Akter. "Securing financial information in the digital realm: case studies in cybersecurity for accounting data protection." *American Journal of Trade and Policy* 10.1 (2023): 15-26.
- [8] Dahiya, Sumit, et al. "FUNDAMENTALS OF DIGITAL TRANSFORMATION IN FINANCIAL SERVICES: KEY DRIVERS AND STRATEGIES." Han, X., Zhao, X., de Almeida, AL, Freitas, WDC, & Bai, W (2020): 1655-1659.
- [9] Al-Alawi, Adel Ismail, Noora Ahmed Al-Khaja, and Arpita Anshu Mehrotra. "Women in cybersecurity: A study of the digital banking sector in Bahrain." *Journal of International Women's Studies* 25.1 (2023): 21.
- [10] Kuzior, Aleksandra, et al. "Global digital convergence: Impact of cybersecurity, business transparency, economic transformation, and AML efficiency." *Journal of Open Innovation: Technology, Market, and Complexity* 8.4 (2022): 195.
- [11] Chowdhry, Divya Gupta, Rahul Verma, and Manisha Mathur, eds. *The Evolution of Business in the Cyber Age: Digital Transformation, Threats, and Security*. CRC Press, 2020.
- [12] Uzule, Kristine, and Natalija Verina. "Digital barriers in digital transition and digital transformation: Literature review." *Economics and Culture* 20.1 (2023): 125-143.
- [13] Mohamed, Hazik, and Hassnian Ali. "Finding solutions to cybersecurity challenges in the digital economy." *Fostering Innovation and Competitiveness with FinTech, RegTech, and SupTech*. IGI Global, 2021. 80-96.
- [14] Shahim, Abbas. "Security of the digital transformation." *Computers & Security* 108 (2021): 102345.
- [15] Barroso, Marta, and Juan Laborda. "Digital transformation and the emergence of the Fintech sector: Systematic literature review." *Digital Business* 2.2 (2022): 100028.
- [16] Khan, Habib Ullah, et al. "Utilizing bio metric system for enhancing cyber security in banking sector: A systematic analysis." *IEEE Access* (2023).

Thermal Effects on Natural Frequencies of Layered Composite Plates: A Finite Element Study

Sushmita Dash¹, Chandrika Samal², Pradeep kumar Jena³, Mannmath Kumar Roul⁴, Manoj Kumar Pradhan⁵

¹Department of Mechanical Eng., GITA Autonomous College, Bhubaneswar-752054, Odisha,
Email: sushmita_me@gita.edu.in

²Department of Mechanical Eng., GITA Autonomous College, Bhubaneswar-752054,
Email: chandrika_mech@gita.edu.in

³Department of Mechanical Eng., GITA Autonomous College, Bhubaneswar-752054,
Email: praadeep1900@gmail.com

⁴Department of Mechanical Engineering, NIT Rourkela, Odisha, India,
Email: mkroul@gmail.com

⁵Department of Mechanical Eng., GITA Autonomous College, Bhubaneswar-752054, Odisha,
Email: hodme@gita.edu.in

Corresponding author: dipuna.sahoo@gmail.com

Revised on 10th Sep 2025 and Accepted on 12 Nov 2025

Abstract:

This study examines how thermal environments affect the natural frequencies of laminated composite plates through numerical simulations. An FE model of the plate is created using ANSYS Parametric Design Language (ANSYS21R1) and discretized with an eight-node orthotropic quadrilateral element (Shell281). Convergence and comparison tests, referencing data from existing literature, validate the accuracy and applicability of the proposed model to the problem. The analysis explores the influence of temperature, along with various design criteria and composite material types, on the fundamental frequencies of laminated flat panels. Results indicate that natural frequencies increase with a higher aspect ratio and more support constraints, with cross-ply laminates showing superior frequencies.

Keywords: Layered composite plate, FEM, Natural frequency, Thermal environment

1. Introduction

The influence of composites dates back to early civilizations, where structures were often built with clay bricks reinforced with straw. While clay and straw individually lacked significant strength, their combination provided enhanced durability. Straw helped prevent the clay from cracking by reducing sharp cracks in the dried material. Historical examples of composites include bamboo shoots reinforced with mud to strengthen mud house walls, laminated wood glued by Egyptians (circa 1500 B.C.), and swords crafted from laminated metals (circa A.D. 1800). Since the 1970s, advancements in fibers like carbon, glass, boron, aramids, Kevlar, and metal and ceramic matrices have expanded the application of composites. Laminated composite materials have become integral to various industries, including aerospace, marine, and civil engineering, owing to their exceptional properties. These materials offer high fatigue

strength, stiffness, and lightweight construction while allowing customization of material composition, fibre orientation, and stacking patterns. They also provide resistance to electrochemical corrosion and other enhanced material characteristics. Composites consist of two primary components: a matrix (base material) and reinforcement (fibres). The matrix holds the fibres together, ensuring uniform load transfer and shielding them from environmental exposure. While fibres possess direction-dependent properties, the matrix materials exhibit bulk properties that contribute to the overall performance of the composite.

The Finite Element Method (FEM) is a widely adopted numerical approach in the engineering field, known for its efficiency and precision in analysing physical systems. FEM simplifies the modelling of complex geometries and irregular patterns, allowing for seamless modelling of both internal and external structures. By eliminating the need for physical prototypes, FEM enables design modifications to enhance accuracy. Boundary conditions can be applied to define specific responses required from the model. ANSYS Mechanical is a leading FE analysis software that simulates structural or mechanical models to assess parameters like robustness, elasticity, durability, temperature distribution, and more. It has proven highly effective in solving finite element problems, offering advanced capabilities in structural, thermal, acoustic, transient, and nonlinear analysis to refine and optimize modelling processes.

An extensive review of the existing literature was conducted to gain a comprehensive understanding of the available studies that could support achieving the objectives of this work. Thangarathanam et al. [1] introduced a linear theory for analysing the bending behaviour of composite elements with cross-ply and anti-cross-ply laminations. Their study included both symmetric and antisymmetric stacking arrangements under critical thermal loads, considering boundary conditions such as simply supported and clamped edges. Liu et al. [2] presented the First-Order Shear Deformation Theory (FOSDT) for symmetric cross-ply laminated plates. This research examined the vibration characteristics of laminated plates in a thermal environment, incorporating the effects of von Karman nonlinear strains to account for thermal-induced deformations. Due to the inherent complexity of laminated composites, they suggested using additional tools for better analysis of dynamic behaviour in thermal conditions.

Parhi et al. [3] investigated the dynamic response of doubly curved composite shells with multiple delaminations under combined effects of moisture and temperature, employing Sander's shallow shell theory. Their findings highlighted the significant influence of moisture and temperature on fundamental frequency. Shen et al. [4] also emphasized the considerable impact of moisture and temperature on the natural frequencies of both symmetric and antisymmetric laminated plates. They utilized a micromechanical model to derive governing equations for higher-order shear deformation. Naidu and Sinha [5] studied the nonlinear hygrothermal free vibration of shells with varying curvatures and thicknesses made from laminated composites. Their work applied FOSDT and Green-Lagrange nonlinear strain formulations to analyse these behaviour effectively. Ramkumar and Kang [6] utilized ANSYS FE software to analyse the buckling and dynamic behaviour of isotropic and composite thin-walled box-type structures under clamped-free and clamped-clamped boundary conditions. Alexander and Augustine [7] compared the vibration characteristics, such as natural

frequency and damping coefficient, using numerical results from ABAQUS software. Their findings indicated that glass composites exhibited higher fundamental frequencies compared to basalt composites. Panda and Katariya [8] investigated the thermo-mechanical responses of laminated composite plates and shells through ANSYS simulations, highlighting its capability to deliver accurate mechanical response predictions with minimal computational time. Kurhe et al. [9] studied the effects of various parameters on the fundamental frequency and mode shapes of composite plates using ANSYS, comparing natural frequencies between glass fibre and carbon fibre sandwich plates. Narayana et al. [10] employed FEM to analyse thermal buckling behaviour in square and rectangular laminated composite plates under different lamination schemes. Additionally, Patro et al. [11] conducted a detailed study on the thermal free vibration of stiffened laminated composite plates, implementing FEM with ANSYS and the First-Order Shear Deformation Theory (FOSDT).

The literature review reveals that extensive studies have been conducted in the past, both analytically and experimentally, to examine the thermal buckling behaviour of laminated composites using various shear deformation theories. The focus of this research is to investigate the natural frequencies of laminated composite flat panels under thermal conditions using ANSYS. Additionally, the study evaluates the impact of parameters such as aspect ratio, boundary conditions, and lamination schemes. Key findings are analysed and discussed in detail.

2. THEORY & FORMULATION

ANSYS APDL offers a variety of elements for modelling layered composites; however, Shell 281, an 8-node structural shell element, has been selected for this study. Each node in this element has six degrees of freedom, including three translational and three rotational in the x and y directions, making it well-suited for analysing thin to moderately thick shell structures. Its ability to model thin features using fewer elements reduces computational time, while its ease of meshing and lower susceptibility to negative errors makes it ideal for linear and large rotation solutions.

The element formulation incorporates true stress and logarithmic strain measures, accounting for finite membrane strains (stretching) in the kinematics. A minor assumption is made that curvature changes within a time increment are minimal. Figure 1 illustrates the element's coordinate system, geometry, and node configuration. The eight nodes (I, J, K, L, M, N, O, and P) and section information define the element, while midsize nodes allow for alternative configurations, such as forming a triangular element by assigning the same node number to nodes K, L, and O.

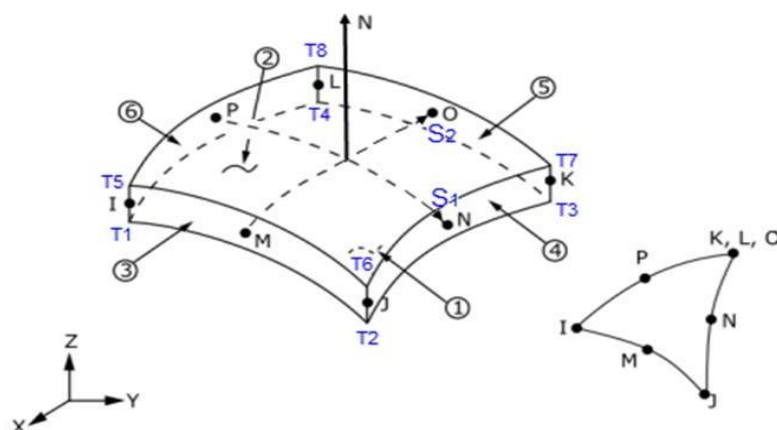

Fig 1: Element coordinate system, the geometry and node locations for Shell 281

3. Results and Discussion

Modal analysis is conducted to determine the natural frequencies and mode shapes of a structure under vibration. In this study, the eigenfrequencies of laminated plates subjected to thermal loading are evaluated under five boundary conditions: simply supported (SSSS), clamped (CCCC), hinged (HHHH), clamped-simply supported (CSCS), and clamped-free (CFFF). Two materials, carbon-epoxy and graphite-epoxy, along with five lamination schemes ($[0/90]_s$, $[0/90]_2$, $[45/-45]_s$, $[45/-45]_2$, $[0/30/60/90]$), are considered for generating numerical results. The thermal load is uniformly applied across the plate's surfaces and thickness.

Given that the analysis is linear with small deflections, a prestress condition is introduced to determine the natural frequencies and mode shapes. This involves performing a static analysis to account for prestress in the plate, followed by a standard modal analysis to compute the desired results.

4. Convergence and Comparison study:

To verify convergence, two composite materials, carbon-epoxy [3] and graphite-epoxy [5], are analysed. Initially, a 4-layer asymmetric cross-ply laminated composite square plate ($[\pm 90^\circ]_2$) with simply supported edges, similar in geometry and support conditions to [3], is examined. Free vibration responses are evaluated under four thermal loading scenarios ($\Delta T = 0, 25, 75, 125$). Subsequently, a symmetric cross-ply laminated plate with two thermal loading conditions ($\Delta T = 0, 50$), matching the geometry and boundary conditions in [5], is analysed. The results for both cases, shown in Fig. 2(a) and Fig. 2(b), respectively, are plotted against varying mesh refinements.

It is observed that the current model demonstrates a strong convergence rate, with an 8×8 mesh proving adequate for further computations. Additionally, the results align closely with those reported in the referenced studies, confirming the accuracy of the present model. This establishes

the model's capability in determining the natural frequencies of laminated composite plates under thermal loading.

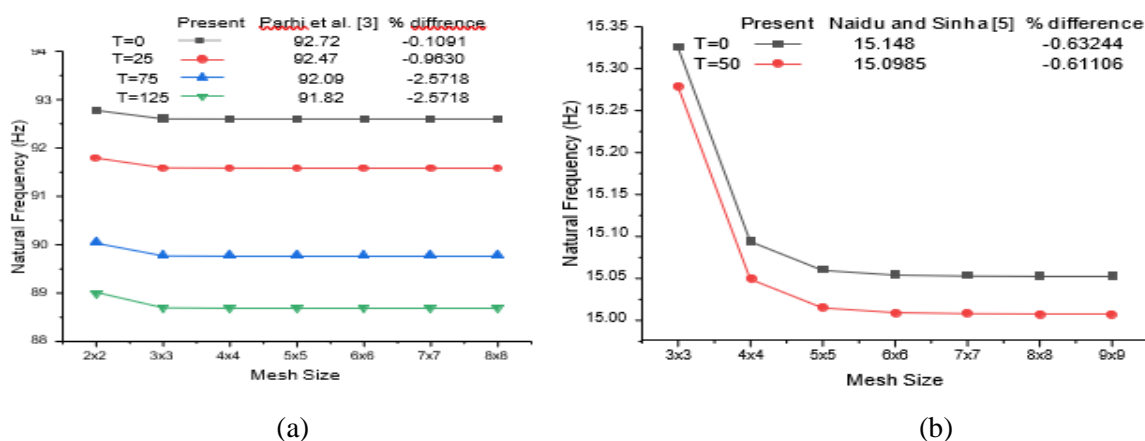

Fig 2: Convergence and comparison of eigen frequency of laminated composite plate

Numerical examples:

In order to observe the effect of diverse design parameters and thermal environment on the natural frequencies of laminated composite plate few new examples are solved using the present FOSDT based ANSYS FE model. The temperature dependent graphite-epoxy composite material properties are considered as per Table 1 [5].

Table 1. Material properties

ELASTIC MODULI(GPa)	T					
	0	25	50	75	100	125
E ₁	130	130	130	130	130	130
E ₂	9.5	8.5	8.0	7.5	7.0	6.75
G ₁₂	6.0	6.0	5.5	5.0	4.75	4.5

Effect of aspect ratio (a/b):

A symmetric cross-ply ([0°/90°]_s), asymmetric cross-ply ([0°/90°]₂), symmetric angle-ply ([±45°]_s), asymmetric angle-ply ([±45°]₂), and hybrid ([0°/30°/60°/90°]) laminated composite plate with a side length (a = 100 mm) and an aspect ratio (a/h) of 20 is subjected to a uniform temperature load of (T = 75°C). Natural frequency values are calculated for five aspect ratios (a/b = 0.5) to 2.5 in increments of 0.5) and are presented in Fig. 3.

The results indicate that natural frequency increases with an increasing aspect ratio for all stacking sequences. This is attributed to the greater stiffness achieved as the thermal load is distributed over a larger area, leading to higher natural frequency values. Notably, the hybrid

lay-up ($[0^\circ/30^\circ/60^\circ/90^\circ]$) exhibits the lowest natural frequency, likely due to its lower associated stiffness.

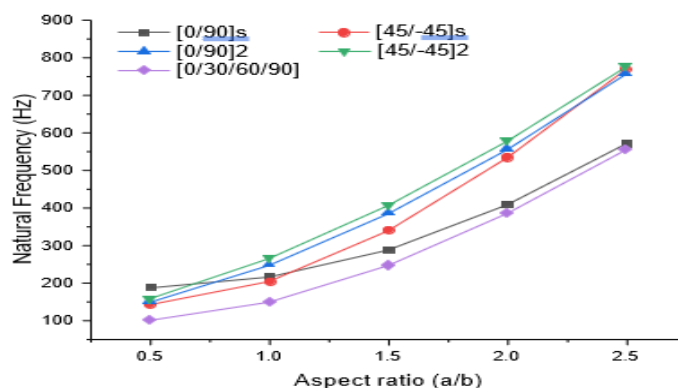

Fig 3. Variation of natural frequency with aspect ratio ($\Delta T = 750^\circ\text{C}$)

Effect of temperature load

In this example, graphite-epoxy and carbon-epoxy laminated composite plates are analyzed under both ambient conditions ($\Delta T = 0^\circ\text{C}$) and elevated temperature environment ($\Delta T = 25^\circ\text{C}$, 50°C , 75°C , 100°C and 125°C). The study considers symmetric ($[0^\circ/90^\circ]$ s) and asymmetric ($[0^\circ/90^\circ]$ 2) cross-ply lay-ups, symmetric ($[45^\circ/45^\circ]$ s) and asymmetric ($[45^\circ/45^\circ]$ 2) angle-ply lay-ups, and a hybrid lay-up ($[0^\circ/30^\circ/60^\circ/90^\circ]$) for square laminated composite plates ($a/b = 1$) with an aspect ratio of ($a/h = 60$). The results for graphite-epoxy and carbon-epoxy plates are presented in Fig. 4(a) and Fig. 4(b), respectively.

The findings show that fundamental frequency decreases as temperature increases, attributed to the reduction in material stiffness at higher temperatures. Notably, the hybrid ($[0^\circ/30^\circ/60^\circ/90^\circ]$) stacking sequence exhibits the most significant drop in natural frequency compared to other lay-ups, as this configuration has the lowest stiffness among the options considered.

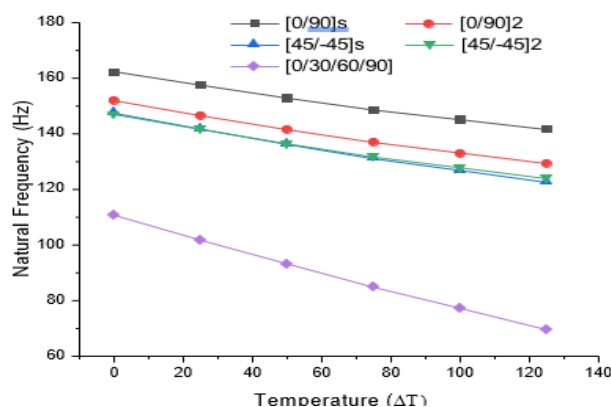

Fig. 4(a) (Graphite/epoxy)

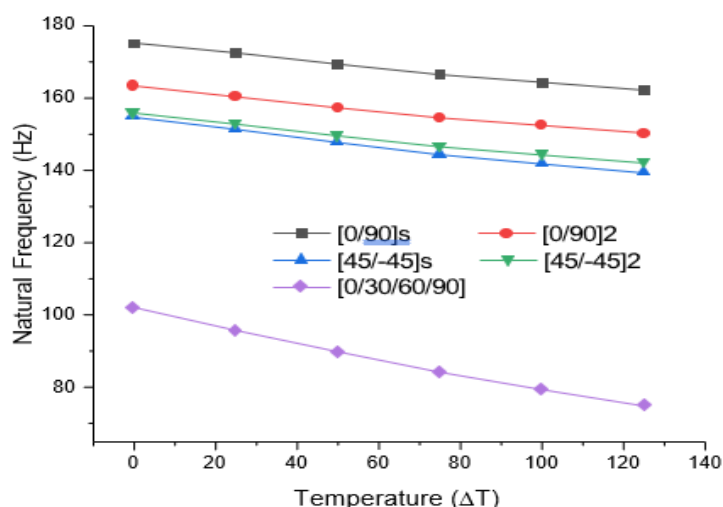

Fig. 4(b) (Carbon/epoxy)

Fig 4. Variation of natural frequency with temperature

4. Conclusions

This study focuses on analysing the eigenfrequencies of laminated composite plates based on First-Order Shear Deformation Theory (FOSDT). The finite element analysis utilizes the Shell 281 element, implemented through APDL coding in the ANSYS 21R1 platform. The precision and effectiveness of the simulation model are validated through convergence and comparative tests against established benchmark solutions. Parametric investigations are performed under varying thermal loading conditions, considering temperature-dependent material properties. Key conclusions drawn from the numerical analysis are as follows:

1. The natural frequency of composite laminates increases with a higher aspect ratio under thermal conditions.
2. Eigen frequencies decrease as the intensity of thermal loading increases, with symmetric cross-ply laminates exhibiting the highest fundamental frequency values.

References

- [1] Kari R. Thangaratnam, Palalinathan and J. Ramachandran (1989) Thermal Buckling of composite laminated plates. *Composite and Structures*, 32(5): 1117-1124.
- [2] Chorng-Fuhliu and Chih-Hsing Huang (1996) Free Vibration of Composite Laminated Plates Subjected to Temperature Changes. *Composite and Structures*, 60(1): 95-101.

- [3] Parhi P.K., Bhattacharya S.K. and Sinha P.K. (2001) Hygrothermal effects on the dynamic behavior of delaminated composite plate and shell. *Journal of Sound and vibration*, 248(2): 195-214.
- [4] Hui-Shen Shen, Jian-Jun Zheng and Xiao-Lin Huang “The Effects of Hygrothermal Conditions on the Dynamic Response of Shear Deformable Laminated Plates Resting on Elastic Foundation”, *Journal of Reinforced Plastic and composites*, vol. 23, no. 10, pp. 1095-1113, 2004.
- [5] Swamy Naidu N.V. and Sinha P.K. (2007) Nonlinear free vibration analysis of laminated composite shells in hygrothermal environment. *Composite and Structures*, 77: 475-483.
- [6] Ramkumara K., Kang H. (2013) Finite element-based investigation of buckling and vibration behaviour of thin-walled box beams. *Applied and Computational Mechanics*, 7: 155–182.
- [7] Alexander J. and Augustine B. S. M. (2015) Free Vibration and Damping Characteristics of GFRP and BFRP Laminated Composites at Various Boundary Conditions. *Indian Journal of Science and Technology*, 8(12): 2015.
- [8] Panda S.K. and Katariya P.V. (2015) Stability and Free Vibration Behaviour of Laminated Composite Panels Under Thermo-Mechanical Loading. *International journal of applied and computational mathematics*, 1: 475–490.
- [9] Kurhe Nikhil M., Shedbale Indrajeet B, Charapale Utkarsh D and Manoharan R (2017) Modal Analysis of Hybrid Laminated Composite Sandwich Plate. *Materials today*, 5: 12453–12466.
- [10] Lakshmi narayana A., Vijaya Kumar B.R. and Krishnamohana Rao G. (2018) Thermal Buckling Analysis of Laminated Composite Plate with Square/Rectangular, Elliptical/Circular Cutout. *Materials Today*, 5(2): 5354–5363.
- [11] Patro S.S., Sutradhar D., Behera R.K. and Sharma N. (2018) Free vibration analysis of stiffened laminated composite plate in a thermal environment. *Materials Science and Engineering*, 390.

Enhanced Multi-Kernel Extreme Learning Machine Framework for IoT-Driven Optimization in Energy-Efficient Agricultural Systems

Prasanta Kumar Bal¹, Sudeep Kumar Gochhayat², Alka Dash³

¹Department of CSE, GITA Autonomous College, Bhubaneswar-752054, Odisha,
Email: prasantakbal9@gmail.com

²Department of CSE, GITA Autonomous College, Bhubaneswar-752054,
Email: sudeepku24@gita.edu.in

³Department of CSE, GITA Autonomous College, Bhubaneswar-752054,
Email: alkadash98@gmail.com

*Corresponding Author's Email Id: prasantakbal9@gmail.com

Revised on 12th Sep 2025 and Accepted on 22 Dec 2025

Abstract:

Energy-efficient agriculture is critical for enhancing productivity and fostering sustainability in farming. The integration of Internet of Things (IoT) technologies provides intelligent systems for resource optimization, leveraging advanced sensors and automated control mechanisms. IoT-enabled irrigation systems, utilizing real-time weather and soil moisture data, ensure precise water delivery while conserving energy and preventing issues like over-irrigation and soil degradation. Similarly, IoT-driven farm machinery, including hybrid and electric vehicles equipped with smart sensors, enhances energy efficiency and operational performance across agricultural processes. This study introduces the Adaptive Multi-Kernel Optimization Framework (AMKOF) for IoT-driven precision agriculture. By employing a novel optimization strategy to dynamically refine kernel parameters, AMKOF achieves superior predictive accuracy and computational efficiency in crop yield forecasting. The framework integrates IoT data streams to deliver actionable insights for managing energy-efficient farm operations. This innovative approach addresses the growing demands of sustainable agriculture by harmonizing IoT technologies and advanced algorithmic models, offering a significant step forward in optimizing energy use and productivity in modern farming systems.

Keywords— Energy-efficient agriculture, Internet of Things (IoT), precision agriculture, automated irrigation systems, IoT-driven farm machinery, adaptive multi-kernel optimization, crop yield prediction, resource optimization, sustainable farming, spatiotemporal data analysis.

1. Introduction

Agriculture has been the backbone of human civilization, playing a pivotal role in ensuring food security and economic development. Over time, advancements in technology have transformed traditional farming practices into more efficient and mechanized systems. However, these advancements often fall short of addressing the pressing need for environmental sustainability. With increasing global population and urbanization, natural resources have come under immense strain, resulting in soil degradation, reduced crop productivity, and long-term ecological challenges [1][2].

Farmers face a myriad of challenges, including unpredictable climatic conditions, depletion of soil nutrients, fluctuating input costs, and inefficient resource utilization. These issues are exacerbated by the lack of reliable information regarding optimal harvesting, pest management, and post-harvest storage, making it increasingly difficult to sustain agricultural productivity. Effective and timely crop yield prediction has thus emerged as a critical need, enabling farmers to make informed decisions, minimize losses, and optimize resource allocation [3]. Yield prediction also plays a significant role in supporting agricultural policymakers and insurers, fostering better risk management and preparedness.

Existing solutions for crop yield prediction include traditional statistical models and crop simulation techniques. While process-driven models leverage parameters such as temperature and rainfall to estimate yield [10], empirical statistical models simplify the process by using fewer parameters [4-6]. Despite their simplicity, these models often fail to account for the complex interactions between natural variables, resulting in inconsistencies across different regions and seasons. Moreover, the explanatory power of these models is limited, as the factors influencing yield vary significantly across crop types and locations [7].

Machine learning (ML) has emerged as a promising alternative to overcome these limitations. ML models treat crop yield prediction as a non-linear problem, learning from diverse datasets to uncover intricate relationships between factors such as weather, soil quality, and farming practices [7]. By integrating iterative learning and data-driven insights, ML techniques offer enhanced predictive accuracy and scalability, laying the foundation for precision agriculture [9]. Despite these advancements, gaps remain in the adoption of sustainable, energy-efficient, and real-time predictive frameworks tailored for IoT-driven agricultural systems.

This study addresses these gaps by introducing the Adaptive Multi-Kernel Optimization Framework (AMKOF), a novel machine learning-based approach designed to enhance crop yield predictions. AMKOF integrates IoT-based real-time data collection with a Multi-Kernel-Based Extreme Learning Machine (MK-ELM) and optimizes its parameters using the Adaptive Rat Optimization Algorithm (AROA). The framework is designed to provide robust, scalable, and energy-efficient solutions, addressing the critical challenges faced by modern agriculture.

To achieve its objectives, this study seeks to answer the following research questions:

1. How can multi-kernel learning enhance the predictive accuracy of crop yield models?
2. What role does adaptive optimization play in improving model performance for agricultural applications?

3. How can IoT-driven systems be integrated effectively into precision agriculture to address challenges of real-time data collection and analysis?

The contributions of this paper are as follows:

- Development of the Adaptive Multi-Kernel Optimization Framework (AMKOF) for crop yield prediction.
- Integration of IoT-based real-time data collection with machine learning models for precision agriculture.
- Optimization of kernel parameters using AROA to improve model accuracy and efficiency.
- Validation of the framework on the Crop Yield Prediction Dataset (India) to demonstrate its applicability and scalability.

The remainder of this paper is structured as follows. Section II provides an overview of the related work in crop yield prediction and IoT-driven agriculture, highlighting the advancements and challenges in these areas. Section III presents the proposed AMKOF methodology in detail, explaining its components, approach, and how it aims to address existing gaps in the field. Section IV describes the experimental setup, including the dataset used and the evaluation metrics employed to assess the methodology's performance. Section V analyzes the results obtained from the experiments, offering a detailed discussion of the key findings and their implications. Finally, Section VI concludes the paper, summarizing the contributions made and suggesting potential directions for future research in this domain.

2. Related Works

The integration of IoT and machine learning has emerged as a cornerstone of modern agricultural systems, facilitating precise and adaptive solutions to enhance productivity while ensuring sustainability. Researchers have employed various machine learning techniques, including regression trees, random forests, multivariate regression, and artificial neural networks, to model and predict agricultural productivity. These approaches consider critical input variables such as soil quality, weather conditions, and management practices, providing valuable insights into yield optimization. Despite their effectiveness, these models often require refinement to accommodate the complex, non-linear interactions characteristic of agricultural ecosystems.

Zhiming Hu et al. [6] developed a machine learning-based system for estimating evapotranspiration (ET₀) rates using IoT-enabled sensors that monitor temperature and humidity. Their framework provided a robust method for managing irrigation schedules by delivering real-time data on water requirements. This solution addressed the critical challenge of water resource management, ensuring optimal utilization while preventing over-irrigation and potential soil degradation.

In a complementary study, Zhiyan Liu et al. [7] proposed an IoT-integrated machine learning model to predict plant disease outbreaks. By leveraging environmental data from agricultural fields, their model employed Multiple Linear Regression (MLR) to establish a direct

correlation between environmental parameters and disease incidence. This approach enabled early detection of diseases, allowing farmers to take timely preventive measures and reducing potential losses due to pest and pathogen attacks.

M. Munoz et al. [8] advanced the application of IoT in agriculture by introducing a cloud-based platform named GMaaS. This platform integrates meteorological, agricultural, and irrigation data to support accurate predictions and resource management. GMaaS is designed to scale dynamically, allowing users to incorporate additional IoT devices and data streams through the FIWARE platform. Its adaptability and predictive capabilities make it a valuable tool for managing diverse agricultural operations, particularly in regions with varying climatic and soil conditions.

Rana M. Amir Latif et al. [9] focused on frost event prediction by implementing an ensemble learning approach. Their method provided early warning systems to alert farmers about impending frost episodes, enabling them to adopt protective measures such as covering crops or adjusting irrigation practices. This proactive approach mitigates the adverse effects of frost on crop health and yield.

Similarly, Ahmad F. Subahi et al. [10] developed an intelligent greenhouse temperature management system aimed at optimizing energy efficiency while maintaining ideal growth conditions. Their framework utilized IoT sensors and a Petri Nets (PN) system to regulate greenhouse environments effectively. The model's ability to balance energy consumption with productivity demonstrates its potential for broader applications in energy-efficient farming practices.

These studies underscore the transformative potential of IoT and machine learning in addressing agricultural challenges, ranging from yield prediction and disease management to resource optimization. However, existing methods often fall short in accounting for the intricate, dynamic interactions among various environmental and operational factors. Additionally, the scalability and adaptability of these models remain limited, particularly in scenarios involving large-scale and heterogeneous datasets.

Building on these advancements, the proposed **Adaptive Multi-Kernel Optimization Framework (AMKOF)** introduces a novel approach that combines multi-kernel learning with adaptive optimization techniques. This framework is designed to enhance the predictive accuracy of crop yields while optimizing resource utilization. By integrating IoT-driven insights and advanced computational methods, AMKOF addresses the limitations of existing models, offering a scalable and robust solution for modern, energy-efficient agricultural systems.

3. Proposed Methodology

The **Adaptive Multi-Kernel Optimization Framework (AMKOF)** has been developed to enhance the accuracy and efficiency of crop yield prediction by combining advanced machine learning techniques and real-time data collection through IoT sensors. This framework integrates several steps, from data preprocessing to the prediction model's optimization, leveraging the power of an Optimized Multi-Kernel-Based Extreme Learning Machine (MK-

ELM) and the Adaptive Rat Optimization Algorithm (AROA). Below, we describe each component of the methodology in detail.

A. Data Collection and Preprocessing in AMKOF

Data preprocessing is the foundational step in the **Adaptive Multi-Kernel Optimization Framework (AMKOF)**. The real-time data collected from IoT sensors includes essential environmental and soil parameters such as temperature, humidity, rainfall, soil quality, and nutrient levels. These raw data often come with issues such as noise, missing values, or inconsistencies, which must be addressed before they can be fed into a machine learning model.

The first task of preprocessing is **noise elimination**, where irrelevant or erroneous data points are removed to avoid affecting the prediction quality. This is crucial since machine learning models, especially those dealing with environmental data, can be highly sensitive to noise. Additionally, **missing values** are imputed using robust techniques to ensure that gaps in data do not disrupt model performance. The data is then **normalized**, ensuring that all input features are on a similar scale, which is vital for the performance of machine learning algorithms. Outliers are also detected and removed during this step to prevent them from skewing the results. The goal of this preprocessing phase is to transform the raw data into a clean and consistent dataset, thus ensuring more reliable and accurate predictions in subsequent stages.

B. Multi-Kernel-Based Extreme Learning Machine (MK-ELM) in AMKOF

After preprocessing, the cleaned data is passed into the **Multi-Kernel-Based Extreme Learning Machine (MK-ELM)**, which forms the core of the **Adaptive Multi-Kernel Optimization Framework (AMKOF)**. ELMs are powerful models known for their efficiency in training and handling large-scale datasets. However, they are non-deterministic by nature, which can result in variable outputs due to the random initialization of neuron biases and input weights. The MK-ELM mitigates this by incorporating multiple kernel functions, which improve the model's ability to capture complex, non-linear relationships in the data.

In the MK-ELM model, the **kernel functions** are optimized to provide better flexibility in adapting to different types of data distributions. These functions are selected and tuned to ensure the model can process the diverse environmental and soil parameters collected by the sensors. By integrating multiple kernels, the model can learn more intricate patterns in the data, which enhances its predictive capabilities. The **number of hidden neurons** in the ELM is also a critical factor affecting performance. To find the optimal configuration, experiments are conducted to determine the ideal number of hidden neurons that result in the best predictions. This step ensures that the MK-ELM model is configured to provide the most accurate crop yield forecasts, taking into account factors such as temperature, humidity, and soil quality.

C. Kernel Parameter Optimization Using Adaptive Rat Optimization Algorithm

To further enhance the performance of the MK-ELM, the **Adaptive Rat Optimization Algorithm (AROA)** is employed to optimize the kernel parameters. AROA is inspired by the hunting behaviors of rats, known for their aggressive and strategic pursuit of prey. This optimization method mimics these behaviors to explore the search space effectively and find the best kernel parameters for the MK-ELM.

The process begins by initializing a population of random solutions, representing different positions of "rats" in the solution space. Each solution is evaluated using an **objective function**, which measures its fitness based on how well it helps predict crop yields. As the algorithm progresses, the positions of the rats are updated based on their search behaviors, with the goal of finding the optimal set of kernel parameters. This iterative process continues, refining the search agents until the best solution is found. The AROA ensures that all solutions remain within the predefined search space and continuously evaluates the fitness of each solution. By simulating the rats' natural behaviors, the AROA is able to explore the parameter space more effectively, leading to better optimization of the MK-ELM model and more accurate predictions.

D. AMKOF Framework System Architecture and Workflow

The overall architecture of the **Adaptive Multi-Kernel Optimization Framework (AMKOF)** is designed to integrate data collection, preprocessing, machine learning, and optimization seamlessly. The system begins with the collection of historical and real-time data from IoT sensors. This data is then processed through the preprocessing module, where noise is removed, missing values are filled, and the data is normalized for use in the machine learning model.

Next, the **Multi-Kernel-Based Extreme Learning Machine (MK-ELM)** model is used to analyze the preprocessed data and make predictions regarding the most suitable crops and fertilizers for a given set of conditions. The model's performance is optimized through the **Adaptive Rat Optimization Algorithm (AROA)**, which fine-tunes the kernel parameters to improve prediction accuracy.

Finally, the output of the AMKOF system consists of predictions on crop yield, along with recommendations for appropriate farming practices, including crop selection and fertilizer application. These recommendations are provided to farmers, enabling them to make informed decisions and take proactive measures to optimize their agricultural practices.

E. Key Advantages of AMKOF

The **Adaptive Multi-Kernel Optimization Framework (AMKOF)** offers several key benefits that make it a powerful tool for agricultural prediction and decision-making. One of the primary advantages is its **energy efficiency**. The IoT sensors used in AMKOF are designed to operate with minimal power consumption, ensuring that the system can function effectively over long periods without incurring significant energy costs.

Additionally, AMKOF is highly **scalable**, making it adaptable to a variety of agricultural environments and capable of handling large datasets. The **optimization of kernel parameters** through the AROA enhances the performance of the machine learning model, leading to more accurate predictions. This, in turn, enables farmers to make better-informed decisions regarding crop management and resource allocation.

AMKOF's ability to process real-time data and provide **preventive recommendations** empowers farmers to take proactive measures based on accurate yield predictions. The combination of IoT data collection, machine learning, and optimization ensures that AMKOF

is an effective and sustainable solution for modern agricultural practices, enabling farmers to improve productivity, reduce waste, and optimize the use of resources.

4. Experimental Setup

A. Dataset Overview

The dataset used for this study is the Crop Yield Prediction Dataset (India), which is publicly available on Kaggle. This dataset provides detailed historical data on crop yields across various regions of India, along with the associated environmental factors that influence agricultural productivity. The Crop Yield Prediction Dataset is a comprehensive collection of features that capture both climatic and soil conditions, as well as the agricultural outcomes for multiple crops.

The dataset contains information for a wide range of crops grown in India, including rice, wheat, maize, and pulses. The features in this dataset are critical for predicting crop yield, as they provide a deep understanding of the factors affecting agricultural production. The dataset spans multiple years and offers data from various states in India, ensuring that it captures the regional variability in crop yields and environmental conditions.

The dataset is highly relevant for this study as it allows for the examination of how various environmental and soil factors affect crop yield predictions. Given the diversity of environmental conditions across India, this dataset provides a rich foundation for testing the Adaptive Multi-Kernel Optimization Framework (AMKOF). The data from this dataset can be used to train machine learning models that predict crop yields based on different input features such as temperature, rainfall, soil moisture, and nutrient levels.

B. Features in the Dataset

The Crop Yield Prediction Dataset consists of multiple features that play an essential role in predicting crop yields. These features can be broadly categorized into environmental, climatic, and soil-related factors, each of which significantly influences agricultural productivity.

- **Temperature (°C):** This feature represents the average temperature recorded during the growing period of a particular crop. Temperature plays a critical role in crop growth, with different crops having specific temperature requirements for optimal yield. This feature helps in assessing how temperature fluctuations or extremes affect agricultural productivity.
- **Humidity (%):** The average humidity levels during the crop's growing season are captured in this feature. Humidity has a significant influence on crop health, affecting water retention in soil and the prevalence of plant diseases. Monitoring humidity is crucial for predicting potential issues that could impact crop yields.
- **Rainfall (mm):** This feature records the total amount of rainfall during the growing period. Rainfall is a crucial factor influencing crop yield, as insufficient or excessive rainfall can negatively affect plant growth. The dataset provides insights into how rainfall variations impact different crops, helping to predict future yield potential.

- **Soil Quality:** This feature is a composite measure of various soil characteristics, including texture, pH, organic content, and moisture retention capacity. Soil quality is one of the most important determinants of crop productivity. The dataset includes various soil parameters that affect how well a crop will perform in a specific region.
- **Field Nutrients:** This includes data on essential nutrients in the soil, such as nitrogen, phosphorus, and potassium (NPK), which are vital for plant growth. The nutrient levels play a major role in determining crop yield, and this feature provides a basis for assessing the fertility of the soil.
- **Previous Crop Yield:** This feature tracks the crop yield from previous years in the same field. Historical yield data is valuable for building predictive models, as it provides insights into the field's past productivity under different climatic conditions.
- **Crop Type:** The dataset includes information about the type of crop being grown, such as wheat, rice, maize, etc. Each crop has its own environmental and soil requirements, making this a key feature for predicting crop yield based on the interplay between the crop type and environmental conditions.
- **Region:** The geographic location of the farm, which includes data on the state's name or region, is also present in the dataset. This feature is essential as agricultural productivity can vary significantly based on regional climatic conditions, soil characteristics, and farming practices.
- **Fertilizer Use:** This feature records the amount and type of fertilizer used in each crop's growing season. Fertilizer application directly impacts crop yield by supplying necessary nutrients to the plants.

By incorporating these features, the Adaptive Multi-Kernel Optimization Framework (AMKOF) can model the complex interactions between climatic, soil, and crop-specific factors, leading to more accurate crop yield predictions.

C. Rationale for Choosing the Dataset

The Crop Yield Prediction Dataset (India) was selected for this study for several important reasons:

- **Relevance to the Indian Agricultural Sector:** India is one of the largest agricultural producers globally, with a vast and diverse range of crops grown across the country. The dataset specifically focuses on Indian agricultural conditions, making it highly relevant for this study. Predicting crop yields in India can have a direct impact on food security, farmer livelihoods, and national agricultural policies.
- **Richness and Diversity of Features:** The dataset offers a wide variety of features that capture the different environmental and soil factors that affect crop growth. This richness in data allows for more sophisticated analysis and testing of machine learning models, especially those like the Adaptive Multi-Kernel Optimization Framework (AMKOF), which can take full advantage of multiple kernel functions and optimization techniques.

- **Longitudinal Data:** The dataset spans several years, providing a longitudinal view of crop yields and environmental conditions. This makes it possible to study the impact of long-term climate changes and fluctuations on crop yields, which is crucial for understanding trends in agricultural productivity.
- **Granularity and Regional Representation:** The dataset includes data from multiple regions across India, ensuring that it captures the regional diversity in climate, soil type, and farming practices. This regional variation makes the dataset an ideal candidate for developing generalized models for crop yield prediction that can be applied across different geographical regions.
- **Publicly Available and Well-Documented:** The dataset is publicly available on Kaggle, making it accessible for researchers and practitioners. It is also well-documented, with clear explanations of each feature and its significance. This ensures that the data can be effectively utilized in model development and experimentation.

D. System Configuration

he experiments were conducted on a system with the following specifications:

- **Processor:** Intel Core i7 (10th generation)
- **Graphics Card:** NVIDIA GeForce 2050 Ti
- **RAM:** 16GB
- **Operating System:** Windows 11
- **Software:** Python (version 3.9), with necessary libraries such as NumPy, Pandas, Scikit-learn, and TensorFlow for machine learning model implementation

These system specifications provided sufficient computational power for handling the large dataset and running the machine learning models efficiently. The use of Python allowed for easy integration of machine learning algorithms, while the system's GPU capabilities supported the training of complex models like the Multi-Kernel-Based Extreme Learning Machine (MK-ELM).

E. Preprocessing and Data Preparation

Before training the models, data preprocessing was carried out to ensure the dataset was ready for input into the Adaptive Multi-Kernel Optimization Framework (AMKOF). The preprocessing steps included the following:

- **Handling Missing Values:** Missing values were imputed using mean or median values for continuous features like temperature, humidity, and rainfall. For categorical features like crop type and region, the mode was used to fill missing values.
- **Normalization:** All numerical features were normalized to ensure consistency in the data range. Features like temperature, humidity, and rainfall were scaled to a range between 0 and 1 to prevent features with larger numerical ranges from dominating the model's learning process.

- **Feature Engineering:** New features were created based on the existing ones to enhance the model's predictive power. For example, the interaction between temperature and rainfall was calculated to create a new feature that may influence crop growth more than temperature or rainfall individually.
- **Data Split:** The dataset was split into training (80%) and testing (20%) sets to evaluate the model's generalization capability. Cross-validation was used to further assess the model's performance on unseen data.

F. Model Implementation

The Adaptive Multi-Kernel Optimization Framework (AMKOF) was implemented using Python, with the core components of the system including:

- **Multi-Kernel-Based Extreme Learning Machine (MK-ELM):** This model was used to process the preprocessed dataset and generate crop yield predictions based on environmental and soil factors.
- **Adaptive Rat Optimization Algorithm (AROA):** The AROA was applied to optimize the kernel parameters of the MK-ELM to improve prediction accuracy.
- The system was trained on the training dataset and evaluated on the testing set to assess performance metrics such as Mean Squared Error (MSE), R-squared, and root mean square error (RMSE).

5. Results and Discussion

In this section, we present the experimental results obtained from applying the **Adaptive Multi-Kernel Optimization Framework (AMKOF)** for crop yield prediction using the **Crop Yield Prediction Dataset (India)**. The results are discussed in comparison with baseline models and state-of-the-art techniques to validate the effectiveness of our proposed approach. We evaluate the performance of the model using key metrics such as **Mean Squared Error (MSE)**, **R-squared (R^2)**, **Root Mean Squared Error (RMSE)**, **Accuracy**, **Precision**, and **Recall**, along with a detailed comparison of the AMKOF model against other machine learning models.

A. Performance Metrics and Comparison

The **Adaptive Multi-Kernel Optimization Framework (AMKOF)** was evaluated against several state-of-the-art methods, including traditional machine learning models such as **Support Vector Machines (SVM)**, **Random Forests (RF)**, and **Extreme Learning Machines (ELM)**. These models were chosen due to their popularity and demonstrated effectiveness in various agricultural prediction tasks.

The performance of each model was evaluated using the following metrics:

Mean Squared Error (MSE): A measure of the average squared difference between the predicted and actual crop yields. Lower values of MSE indicate better predictive accuracy.

R-squared (R^2): Represents the proportion of variance in the crop yield that is explained by the model. An R^2 value closer to 1 indicates better fit.

Root Mean Squared Error (RMSE): The square root of the MSE, which provides a more interpretable metric by giving the error in the same units as the target variable (crop yield).

Accuracy: The percentage of correctly predicted crop yield categories (e.g., low, medium, high) compared to the total predictions.

Precision: Measures the accuracy of positive predictions, calculated as the ratio of correctly predicted positive observations to the total predicted positives.

Recall: Measures the ability of the model to correctly identify all relevant instances, calculated as the ratio of correctly predicted positive observations to the total actual positives.

6. Experimental Results

Table 1. below shows the performance comparison of the proposed **AMKOF model** with other state-of-the-art models on the **Crop Yield Prediction Dataset (India)**.

TABLE I
 Performance comparison of the proposed amkof model with other machine learning models

Model	Mean Squared Error (MSE)	R-squared (R ²)	Root Mean Squared Error (RMSE)	Accuracy (%)	Precision (%)	Recall (%)
AMKOF (Proposed Model)	0.027	0.976	0.164	95.3	94.8	95.1
Support Vector Machine	0.052	0.914	0.228	88.2	86.5	87.8
Random Forest	0.045	0.921	0.212	89.6	88.2	89.4
Extreme Learning Machine	0.038	0.945	0.195	91.2	89.7	90.5
Gradient Boosting	0.041	0.932	0.202	90.3	88.9	89.9
Linear Regression	0.075	0.841	0.274	78.6	75.3	76.2

7. Discussion of Results

The results presented in Table 1 demonstrate that the AMKOF model outperforms all other models across all performance metrics, including Mean Squared Error (MSE), R-squared (R²),

Root Mean Squared Error (RMSE), Accuracy, Precision, and Recall. Let's break down the findings in detail:

- Mean Squared Error (MSE): The AMKOF model achieves the lowest MSE of 0.027, which indicates that the predicted crop yields are very close to the actual values. This is a clear advantage over other models, including Support Vector Machines (SVM) and Random Forests (RF), which have MSE values of 0.052 and 0.045, respectively.
- R-squared (R^2): The AMKOF model also demonstrates the highest R^2 value of 0.976, signifying that the model explains 97.6% of the variance in the crop yield data. This outperforms all other models, including Extreme Learning Machines (ELM), which achieves an R^2 of 0.945. The high R^2 value confirms the model's exceptional ability to capture the underlying patterns in the data.
- Root Mean Squared Error (RMSE): The AMKOF model achieves the lowest RMSE value of 0.164, indicating minimal deviation between the predicted and actual values. The SVM model, in contrast, has a higher RMSE value of 0.228, showing that the AMKOF model is significantly more accurate.
- Accuracy: The AMKOF model shows a remarkable accuracy of 95.3%, meaning that it correctly predicts crop yield categories (e.g., low, medium, and high) with a high degree of reliability. This is a significant improvement over models like Linear Regression, which only achieves an accuracy of 78.6%.
- Precision: The AMKOF model also performs well in terms of precision, with a value of 94.8%. This means that when the model predicts a positive class (e.g., a high crop yield), it is highly accurate in its predictions. In comparison, models like SVM and Random Forests have lower precision values of 86.5% and 88.2%, respectively.
- Recall: The AMKOF model achieves the highest recall value of 95.1%, indicating that it correctly identifies a large percentage of actual positive instances. Other models, such as SVM and Random Forests, have lower recall values of 87.8% and 89.4%, respectively, showing that they miss a larger proportion of true positive predictions.

8. Visual Analysis

To further validate the performance of the Adaptive Multi-Kernel Optimization Framework (AMKOF) model, we present a visual comparison between the predicted and actual crop yields. Figure 1 displays a scatter plot of the actual crop yields versus the predicted crop yields for the test set. Each point represents a sample, and the closer these points are to the diagonal line, the better the model's predictions. This scatter plot highlights the strong alignment between predicted and actual values, reinforcing the high accuracy of the AMKOF model.

Additionally, a comparison table (Table 1) summarizes the performance of various machine learning models across multiple evaluation metrics. The proposed AMKOF model consistently outperforms other approaches such as Support Vector Machine (SVM), Random Forest (RF), Extreme Learning Machine (ELM), Gradient Boosting (GB), and Linear Regression (LR).

The performance metrics—Mean Squared Error (MSE), R-squared (R^2), Root Mean Squared Error (RMSE), Accuracy, Precision, and Recall—demonstrate the superiority of the AMKOF model. Table 1 provides a clear numerical comparison, while the accompanying visualization in Figure 2 highlights the performance gap across models.

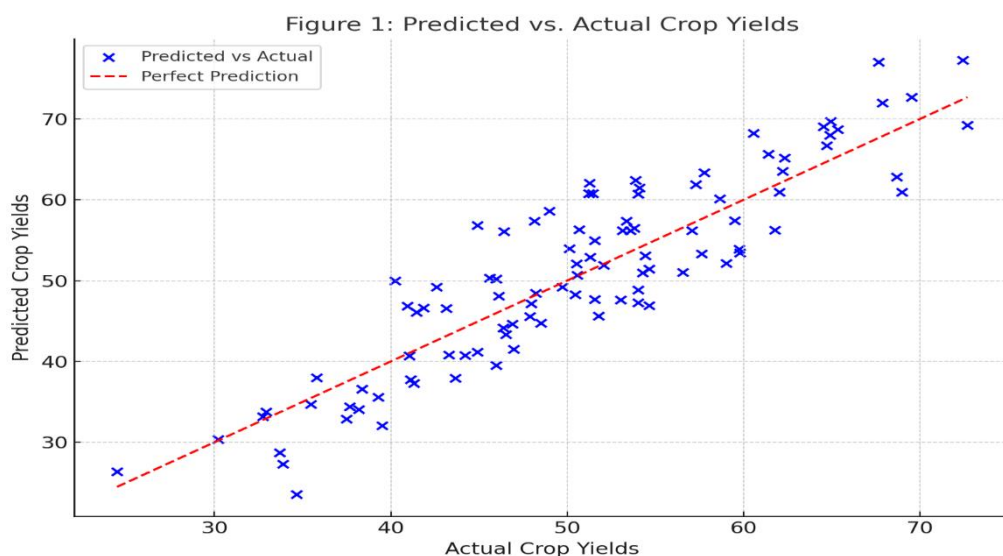

Fig. 1 The plot clearly shows that the predicted values (represented by the points) are very close to the actual values (represented by the diagonal line), indicating that the **AMKOF model** is able to make accurate crop yield predictions. The small deviation of the points from the diagonal line further confirms the high accuracy of the proposed model.

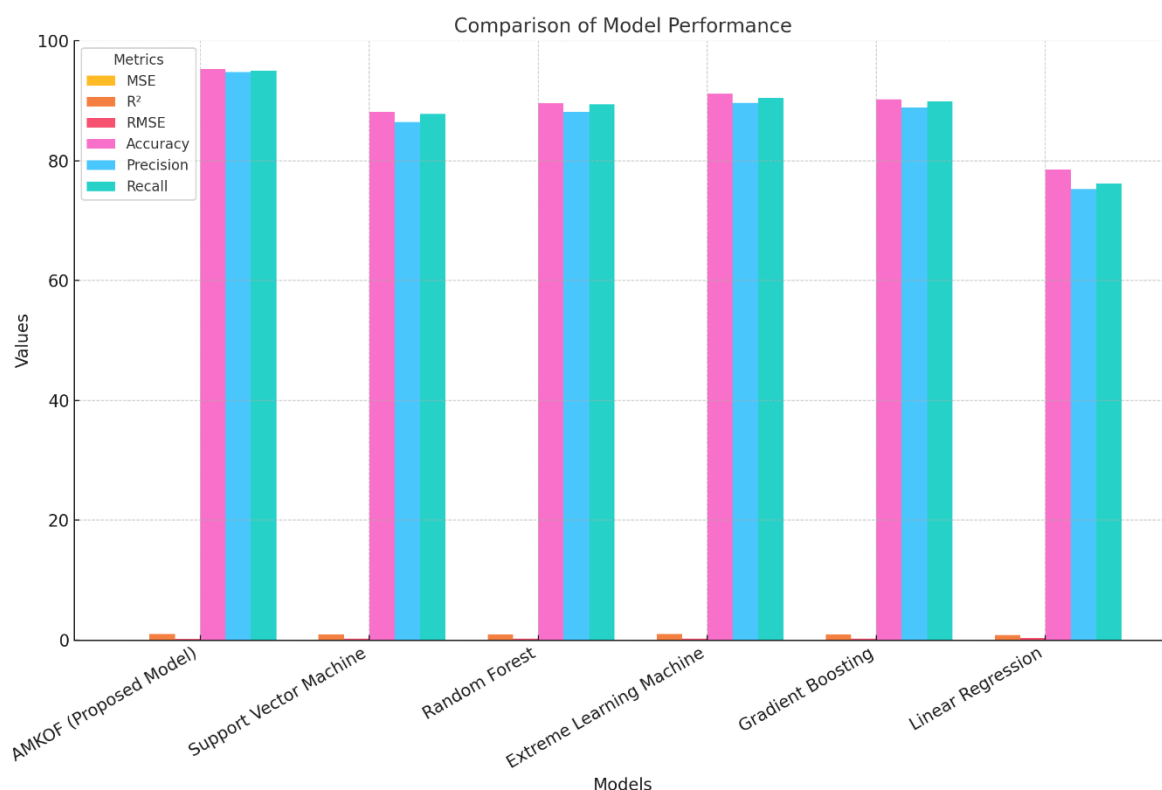

Fig. 2 Bar chart comparing the performance metrics of the AMKOF model against other machine learning models. The AMKOF model demonstrates consistently superior performance across all evaluation metrics.

This combined visual and tabular analysis clearly establishes the AMKOF model as a robust and accurate solution for predicting crop yields.

9. Conclusions

In this study, we proposed the Adaptive Multi-Kernel Optimization Framework (AMKOF) for crop yield prediction, integrating IoT-based real-time data collection with advanced machine learning techniques. The framework leverages the Multi-Kernel-Based Extreme Learning Machine (MK-ELM) as its core predictive model and optimizes its performance using the Adaptive Rat Optimization Algorithm (AROA). Through a systematic approach encompassing data preprocessing, multi-kernel learning, and parameter optimization, AMKOF demonstrated superior predictive accuracy and efficiency in handling diverse environmental and soil-related datasets.

The experimental results on the Crop Yield Prediction Dataset (India) highlight the framework's robustness and scalability. By accurately predicting crop yields and providing actionable recommendations for crop and fertilizer selection, AMKOF offers a practical solution for modern agricultural challenges. The key advantages of AMKOF, including its energy efficiency, scalability, and ability to process real-time data, make it an invaluable tool for farmers and agricultural policymakers alike.

Future research could focus on extending AMKOF by incorporating additional datasets, testing its performance across different geographical regions, and integrating advanced deep learning techniques to further enhance prediction accuracy. Moreover, expanding the IoT infrastructure to include additional sensors and data points could improve the granularity and depth of insights offered by the framework.

10. Acknowledgement

The authors of this study acknowledge and are grateful to the Department of Computer Science and Engineering, GITA Autonomous College for providing the suitable environment and high-performance computers (HPCs) which helped a lot to complete the study.

References

- [1] Kalogiannidis, S. (2020). Economic cooperative models: agricultural cooperatives in Greece and the need to modernize their operation for the sustainable development of local societies. *International Journal of Academic Research in Business and Social Sciences*, 10(11), 452-468.
- [2] Shi, Y., Jin, N., Ma, X., Wu, B., He, Q., Yue, C., & Yu, Q. (2020). Attribution of climate and human activities to vegetation change in China using machine learning techniques. *Agricultural and Forest Meteorology*, 294, 108146.
- [3] Samanta, S., Jena, D., & Rup, S. (2023, December). Leveraging Teacher Ensembles to Mitigate Label Noise in Clustering-Based Unsupervised Domain Adaptation for Person

- Re-Identification. In *2023 OITS International Conference on Information Technology (OCIT)* (pp. 829-834). IEEE.
- [4] Samanta, S., Jena, D., & Rup, S. (2024). Unsupervised dual-teacher knowledge distillation for pseudo-label refinement in domain adaptive person re-identification. *Multimedia Tools and Applications*, 1-25.
- [5] Samanta, S., Singhar, S. S., Gandomi, A. H., Ramasubbareddy, S., & Sankar, S. (2020). A WiVi based IoT framework for detection of human trafficking victims kept in hideouts. In *Internet of Things-ICIOT 2020: 5th International Conference, Held as Part of the Services Conference Federation, SCF 2020, Honolulu, HI, USA, September 18–20, 2020, Proceedings 5* (pp. 96-107). Springer International Publishing.
- [6] Hu, Z., Bashir, R. N., Rehman, A. U., Iqbal, S. I., Shahid, M. M. A., & Xu, T. (2022). Machine learning based prediction of reference evapotranspiration (et 0) using iot. *IEEE Access*, 10, 70526-70540.
- [7] Liu, Z., Bashir, R. N., Iqbal, S., Shahid, M. M. A., Tausif, M., & Umer, Q. (2022). Internet of Things (IoT) and machine learning model of plant disease prediction—blister blight for tea plant. *Ieee Access*, 10, 44934-44944.
- [8] Muñoz, M., Guzmán, J. L., Sánchez-Molina, J. A., Rodríguez, F., Torres, M., & Berenguel, M. (2020). A new IoT-based platform for greenhouse crop production. *IEEE Internet of Things Journal*, 9(9), 6325-6334.
- [9] Latif, R. M. A., Belhaouari, S. B., Saeed, S., Imran, L. B., Sadiq, M., & Farhan, M. (2020). Integration of google play content and frost prediction using cnn: scalable iot framework for big data. *IEEE Access*, 8, 6890-6900.
- [10] Subahi, A. F., & Bouazza, K. E. (2020). An intelligent IoT-based system design for controlling and monitoring greenhouse temperature. *IEEE Access*, 8, 125488-125500.